



## Experimental analysis and combustion characteristics of briquettes from different wood in nigeria



Oluwaseyi O. Alabi<sup>\*</sup>, Timothy A. Adeyi<sup>ORCID</sup>, Sakiru K. Ekun<sup>ORCID</sup>

Department of Mechanical Engineering Lead City University, Ibadan, Nigeria.

\*Corresponding author Email: [alabi.oluwaseyi@lcu.edu.ng](mailto:alabi.oluwaseyi@lcu.edu.ng)

### HIGHLIGHTS

- This research presents an innovative analysis of energy combustion characteristics of various wood briquettes in Nigeria
- The findings offer insights for enhancing energy performance and briquette production efficiency
- Study results could improve briquette production efficiency and contribute to sustainable energy solutions

### ARTICLE INFO

**Handling editor:** Sattar Aljabair

#### Keywords:

Briquettes  
Flame propagation  
Afterglow time  
Calorific value  
Heat combustion

### ABSTRACT

The increasing demand for sustainable and renewable energy sources has prompted extensive research into alternative biomass fuels, particularly in regions like Nigeria, where traditional wood-based fuels are prevalent. A comprehensive experimental analysis of briquettes derived from various wood sources found in Nigeria aims to assess their combustion characteristics and potential as a viable alternative to traditional fuels. The selected wood species include indigenous varieties known for their abundance and accessibility. This study examines the physical and thermal properties of briquettes made from six wood types commonly found in Nigeria: Ayo, Obobo, Obeche, Araba, Afara, and Eku. From the experiment study, the flame propagation rate, afterglow time of the briquettes, calorific value, and heat combustion value 0.72 to 0.73, 408 to 415 sec, 18,745 to 34,857 kJ/kg, and 17079 to 20012 kJ/Kg respectively. The experimental analysis of the briquettes showed that their physical and thermal properties varied, with notable differences in calorific value and propagation rate. The data suggests that the composition and density of wood play a significant role in determining the efficiency and performance of the briquettes. This research addresses the technical aspects of briquette combustion and emphasizes the potential socio-economic and environmental benefits of adopting such alternative fuels. This study's outcomes can guide future initiatives in the quest for cleaner and more sustainable energy practices in Nigeria, aligning with global efforts to mitigate the impact of traditional biomass consumption on the environment and public health.

## 1. Introduction

In recent years, there's been an increased focus on biomass energy production, driven by its reputation as a reliable alternative to fossil fuels. This shift is fueled by concerns about the environmental impacts of fossil fuels, such as greenhouse gas emissions and global warming [1,2], which could arise regarding safety, efficiency, and environmental impact [3]. Biomass energy sources like wood fuel offer a more sustainable option, reducing deforestation and desertification while offsetting the demand for non-renewable energy sources [4]. According to estimates from the United Nations, nearly half of the world's population relies on wood fuel for cooking. This statistic, particularly significant in developing countries, contributes to the increasing environmental challenges of excessive fossil fuel consumption. In the U.S., fossil fuel consumption reportedly accounts for 65% of the nation's greenhouse gas emissions, according to the Environmental Protection Agency [5]. Despite the growing emphasis on sustainable energy, fossil fuels like natural gas still dominate global energy consumption, accounting for a whopping 80% of the world's energy needs. That's a big number that speaks to the scale of the challenge in transitioning to renewable energy sources. The Energy Information Administration (EIA 2019) reports that renewable energy is rising, with a growth rate of 3% annually. This growth is likely due to its lower environmental impact and reduced contribution to global warming. Biomass is a major player in the renewable energy sector, accounting for over 10% of global primary energy use. Biomass is an umbrella term for a variety of fuel types, including combustible biomass and waste (e.g., agricultural residue),

<http://doi.org/10.30684/etj.2024.144659.1640>

Received 27 November 2023; Received in revised form 27 February 2024; Accepted 10 March 2024; Available online 28 March 2024  
2412-0758/University of Technology-Iraq, Baghdad, Iraq

This is an open access article under the CC BY 4.0 license <http://creativecommons.org/licenses/by/4.0>

liquid biofuels (like biodiesel and ethanol), [6] solid biomass (such as wood pellets and charcoal), and gaseous fuels (like biogas and landfill gas) [7,8]. The rapid industrialization of rural areas worldwide, particularly in Nigeria, has exacerbated the concentration of greenhouse gases in the atmosphere.

Greenhouse gases like carbon dioxide, methane, and nitrous oxide are intimately connected, contributing to the buildup of atmospheric gases that trap heat and contribute to global warming [9]. Briquetting is a process that transforms loose wood products into solid, compact blocks of fuel [10]. The main purpose of briquetting is to create a more efficient and transportable form of fuel that is easy to handle and store. It's like taking a pile of wood shavings and compressing them into a log. This process was first developed in the early 20th century and has since become a common practice in many parts of the world, particularly in developing countries. Onukak et al. [11] define briquettes as flammable materials used to start or maintain home fires. Wood-based industries, such as sawmills, produce many wood residues, like branches, stumps, and sawdust, which are excellent for transforming into briquettes. These residues, which would otherwise be discarded as waste, can be transformed into a valuable fuel source through briquetting. These residues would otherwise be left to rot, polluting the air, land, and water. Briquettes have a number of advantages over other forms of bio-fuel, including: Convenience for transportation, environmentally friendly, high calorific value. The calorific value, or energy production, of fuel is a crucial factor in its utility, as it determines the heat generated by a given amount of fuel. A higher calorific value indicates greater energy output [4],[11].

Nigeria has long relied on petroleum products for domestic energy, but this dependence has come at a cost. The price of these products has risen sharply, and they are often hard to come by. In rural Nigeria, most residents traditionally rely on wood-based fuels like charcoal, firewood, and sawdust. According to the Ministry of Energy, Nigeria currently consumes over 5,087 kg of wood fuel annually, and is expected to rise in the coming years as demand continues to increase. Lately, industries and research institutes in Nigeria, like FRIN, have taken an interest in converting sawdust from wood processing into briquettes as an alternative to fossil fuels. If this sawdust could be converted into briquettes, it could be a useful fuel source for domestic cooking and other energy needs.

Biomass waste has great potential to reduce the use of conventional solid fuels and address several pressing environmental problems. An essential consideration in developing an effective wood fuel briquette is balancing moisture content and combustion properties. While moisture content is a key factor, the briquette's ability to burn efficiently and produce sufficient heat is equally important. A briquette must balance these two critical factors to be an effective fuel source. Without this balance, the briquette may not be effective as an energy source or may have undesirable environmental effects. These properties determine how efficiently the briquette will burn and its usefulness as a fuel source [12]. It is important to note that different materials for making briquettes require different conditions for optimal fabrication. Factors such as the type of biomass waste used, the method of briquetting, and the physical and chemical properties of briquettes, all play a role in determining the combustion properties of the final product [12]. Due to the increasing demand for briquettes made from wood materials, numerous esteemed researchers have delved into various aspects of briquetting, including Oladeji et al., [13]. Tembe et al., [14]. Chukwunke et al., [15]. Mong et al. [16], has studied various facets of briquetting, such as the composition of raw materials, their behavior during and after the process, and their characteristics during combustion. The properties of a briquette can be broken down into three main categories: physical properties (like density and porosity), mechanical properties (such as strength and durability), and combustive properties (like heating value and ignition temperature). Depending on the particular property being measured, it can be classified into one of three categories: physical, chemical, or thermal. Physical properties, such as density and porosity, describe the physical characteristics of the briquette. Chemical properties, such as ash content, indicate the chemical composition of the briquette. Thermal properties, such as calorific value, indicate the thermal energy released when the briquette is burned. Each of these categories provides valuable information about the properties of the briquette, which can be used to determine its effectiveness as a fuel source.

This study investigates the combustion properties of wood fuel briquettes, including their calorific value, ash content, and flammability. These properties are important for determining the viability of briquettes as an alternative fuel source. By studying the combustion properties, we can better understand the benefits and limitations of using briquettes as a source of energy. This work thoroughly examined and assessed the combustion characteristics of briquettes produced from wood in Nigeria. In Nigeria, sawdust is a readily available and inexpensive material for briquetting, with several advantages: it is as affordable as wood fuel, it burns efficiently in various types of stoves and boilers, it ignites quickly and burns cleanly, with minimal ash production (1-6%). It is free from sulfur and doesn't produce any odor when burned. It generates a high caloric power of 18,000 kJ/kg, equivalent to medium-grade coal.

## 2. Methodology and briquette production

Although there are numerous sources of briquettes in Nigeria, this study focused on six wood types due to their widespread availability in the country's forests. While a wide range of wood sources could have been considered for this study, the focus was narrowed to six types that are readily available in sawmills: Sawdust from Obeche (*Triplochiton scleroxylon*), Araba (*ceiba Pentandra*), Eku (*Brachystegia* spp), Ayo (*Holoptelia grandis*), Obobo (*Ficus mucoso*), Afara (*Terminelia superba*). These wood types were collected from woodworking industries and sawmills in Nigeria's southwestern region, specifically Oyo state. The materials from the aforementioned sources were air-dried at room temperature (approximately 20 °C) for two weeks, ensuring they were sufficiently dried. To guarantee homogeneity within the particles of each sample, they were sieved through a 600-micron sieve, resulting in uniformly sized particles. The chemical analyses were conducted at the esteemed Institute of Agriculture Research and Training (IAR&T) in Ibadan, Nigeria, utilizing the standard methodology outlined in the official analysis methods.

Cassava starch was used as a binding agent in the production of the briquettes. The sawdust from the six different wood samples weighed 100 g each, and 30 g of moistened starch was added to create a homogeneous mixture. This mixture was then pressed into briquettes using a briquetting machine as shown in Figure 1, creating six replicates for each sample. The prepared briquettes were dried for 21 days, with 7 days of air drying followed by 14 days of sun drying. In Nigeria, a variety of different types of wood are commonly used for the production of briquettes. These include wood species such as teak, iroko, mahogany, and gmelina. Briquettes are typically produced from a mixture of these wood species, which are first chopped or chipped into small pieces and then dried in the sun or in a kiln. Once the wood is dry, it is ground into a fine powder and then pressed into briquettes using a briquette press. The briquettes produced from wood were used as a source of fuel for cooking and heating. Figures 2a and 2b illustrate the wood-derived briquettes that were produced in this study. These briquettes were evaluated for their fuel-related properties, including calorific value, ash content, volatile matter content, and fixed carbon content. These properties were assessed to determine the suitability of the briquettes as a source of fuel. In terms of experimental analysis, several studies have been conducted on the combustion characteristics of briquettes produced from different wood species in Nigeria. These studies have examined the calorific values, burn rates, and emissions of different briquettes. Generally, it has been found that briquettes made from wood species with higher density and oil content tend to have higher calorific values and burn rates, while those made from wood with higher lignin content tend to produce less emissions. However, there is still significant variation in the properties of different briquettes, depending on the exact species of wood used and the manufacturing process.

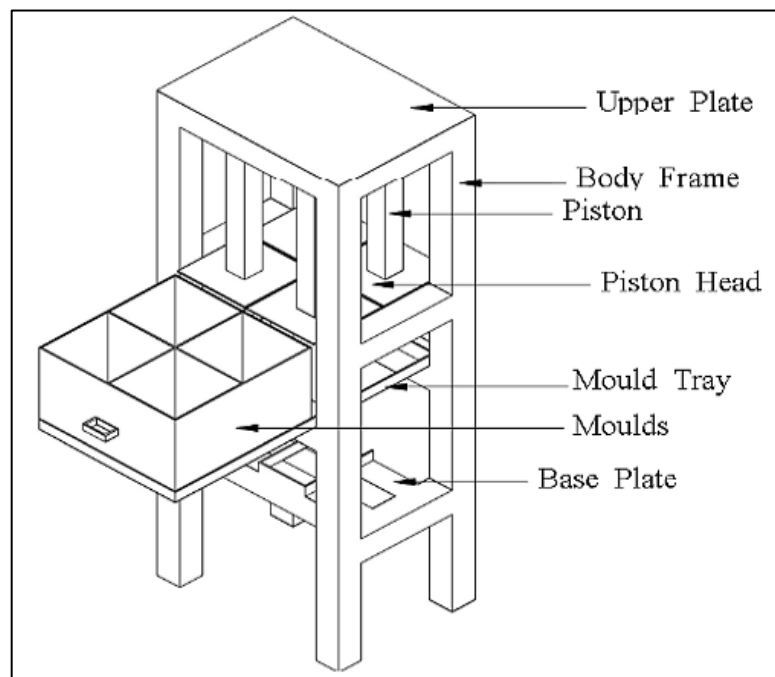

**Figure 1:** Isometric view of an experimental briquetting machine

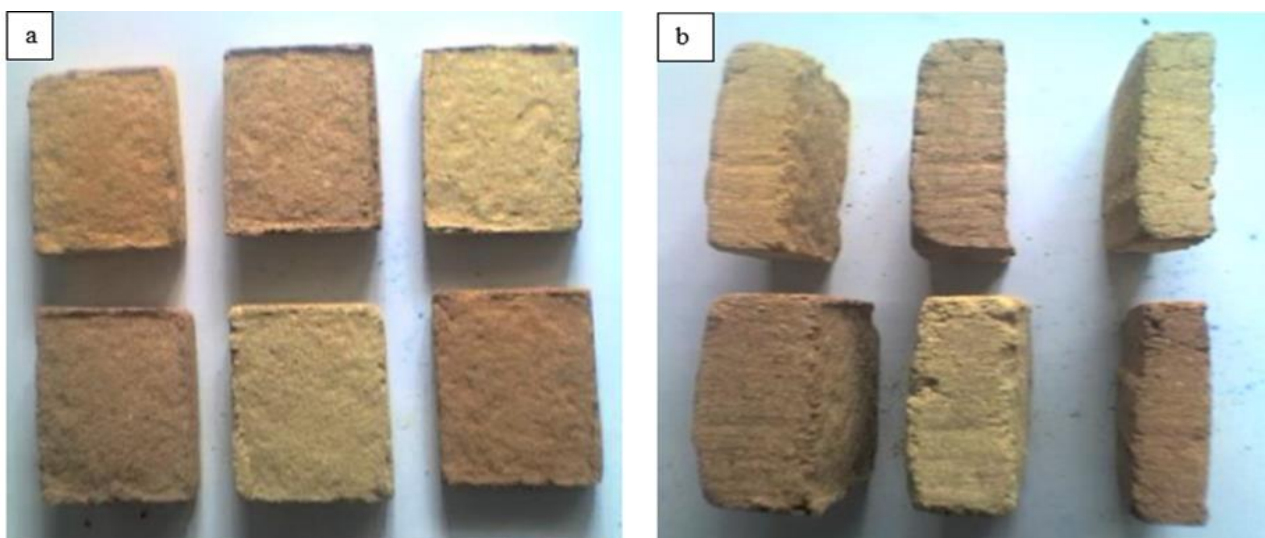

**Figure 2:** (a) Plan view of briquettes made from the six. (b) Side view of briquettes wood species made from the six wood species

## 2.1 Analyzing the spread of combustion in briquettes

The speed at which the flame spread across the briquette samples was measured in a laboratory setting. A single oven-dried briquette was ignited over a Bunsen burner, and the distance it traveled before extinguishing was divided by the elapsed time in seconds to determine the flame propagation test as shown in Equation (1) [3]:

$$\text{Flame propagation test} = \frac{l}{t} \quad (1)$$

where, L = Distance of briquette burnt, T = Time taken to burn in seconds

### 2.1.1 Afterglow time

To determine the duration of the glowing embers after the flame goes out, a piece of oven-dried briquette was ignited over a Bunsen burner, and the time in seconds between the flame going out and the embers ceasing to glow was measured. This is useful for estimating how long a single briquette can maintain heat in cooking and heating applications.

### 2.1.2 calorific value test

The XRY – 1A oxygen bomb calorimeter as shown in Figure 3 was fueled by connecting an industrial oxygen cylinder to the inlet port and slowly opening the valve to allow oxygen to enter the bomb at a pressure range of 2.6 -3.1 MPa. The oxygen flowed into the bomb for one minute to ensure a complete and uniform fuel mixture. The amount of oxygen entering the bomb was carefully monitored to avoid overfilling or underfilling the bomb, which could affect the accuracy of the results. The computer interface was then used to record the weight and composition of the fuel mixture. The bomb was then closed and secured, and the sample briquette was placed inside the bomb, ensuring it was free of any debris or impurities. The lid of the bomb was then closed and sealed, and the calorimeter was ready for testing. The calorific value is determined by measuring the change in temperature of the water in the calorimeter. In contrast, the heat of combustion is determined by the temperature change and the heat capacity of the calorimeter. The specific heat of the water in the calorimeter is known, so the heat of combustion can be calculated by taking the difference between the heat capacity and the measured temperature change. These standard conditions ensure consistency and comparability of calorific values across different types of briquettes and fuel sources. The standard temperature for calorific value determination is 25 °C (298.15 K), while the standard pressure is often set at 1 atmosphere (101.325 kPa or 1.01325 bar). It's important to note that deviations from these standard conditions may require adjustments or corrections in the calorific value calculation to account for the actual operating conditions.



**Figure 3:** XRY – 1A oxygen bomb calorimeter

2.1.3 heat combustion utilization

The heat value of the briquettes was determined using the methodology and formula proposed by [12]. The heat value was calculated by testing the briquettes using a stove to boil 260 grams of water. The data measured included the initial and final mass of the briquettes consumed during the boiling process and the water's initial and final temperature. The heat value was calculated using the following Equations (2 and 3) [12]:

$$\text{Sensible Heat, } Q_s = m_w C_w \Delta T \tag{2}$$

where:  $m_w$  = mass of water (g),  $C_w$  = Specific heat capacity of water (J/g °C),  $\Delta T$  = change in temperature (k)

$$\text{Heat Value, } q = \frac{Q_s}{m_b} \text{ (kJ/g)} \tag{3}$$

where,  $Q_s$  = Sensible heat (kJ),  $m_b$  = weight of the briquettes consumed (g)

3. Results and discussion

The outcomes of the briquette samples' flame propagation rate and weight determinations are presented in Tables 1 and 2, respectively. Table 2 also shows the heat combustion values while the results of the ultimate composition of the six briquette samples, the afterglow time of the briquettes, the calorific value of the briquettes, and the heat combustion value of briquettes examined in the study, which is illustrated in Figures 4, 5, 6, and 7, respectively.

Figure 4 shows the sulphur content of the six briquette samples varied from a low of 0.00% for Obeche to a high of 0.19% for Obobo. The other samples fell within this range, with Ayo, Araba, Afara, and Eku at 0.059%, 0.075%, 0.12%, and 0.19%. Notably, all samples exhibited sulphur content below 1%, which reduces the risk of acid rain caused by sulphur dioxide emissions. On the other hand, Eku has the highest carbon content of 52%, followed by Obobo of 49%, while Afara exhibits a low carbon content of 41.05%. The longer afterglow and slow propagation rate obtained in this study indicate that the briquettes from the six samples ignite easily and burn intensely for a prolonged period, as shown in Figure 5 and Table 1. A higher propagation rate leads to quicker ignition and more intense flames, with heat release increasing proportionally. As a result, higher temperatures and more complete combustion are achieved by Oyelaran et al., [12]. Therefore, slower propagation rates are desirable for better heat generation and efficiency.

Figure 6 exhibits that the briquette samples' calorific value varies from 18,745 KJ/Kg for Obeche to 34,857 KJ/Kg for Ayo. The calorific value of other selected briquette samples is Araba at 23,676 KJ/Kg, Afara at 25,651KJ/Kg, Obobo at 31,570 KJ/Kg, Eku at 32,228 KJ/Kg. It's clear from the data that Ayo has the highest calorific value because it has the lowest moisture content and the highest dry matter content. To sum up, the sample with more dry matter for combustion will generate more energy when burned than 19,534 kJ/kg for briquettes made from palm kernel cake (PKC) [12]. Figure 7 shows the heating value of each briquette. The higher heating values of the briquette samples are 20,012 kJ/kg, 17,079 kJ/kg, 17,389 kJ/kg, 18,013 kJ/kg, 19,026 kJ/kg, and 19,041 kJ/kg for Eku, Araba, Obeche, Afara, Ayo and Obobo respectively. The highest heating value of 20,012 KJ/Kg obtained for Eku is 66.5% that of coal. The energy values obtained for all samples are sufficient to generate heat for household cooking and small-scale industrial applications. Additionally, the combustion characteristics reveal that most of the briquettes meet the minimum calorific value requirement (17500 J/g) to be considered commercially viable, as suggested by [14]. Calorific value alone isn't the only indicator of fuel efficiency, but the burning rate is equally important.

Table 1: Combustible propagation

Briquettes burnt	Distance taken (m)	Time Rate (s)	Propagation (m/s)
EKU	10.8	95	0.113684
ARABA	10.9	96	0.113542
OBECHE	10.8	95	0.113684
AFARA	10.9	95	0.114737
AYO	10.8	96	0.1125
OBOBO	10.7	95	0.72

Table 2: Value of weight briquettes and heat combustion

Sample	Weight of briquettes (g)	Heat Value (kJ/kg)
EKU	106.31	20,012
ARABA	108.10	17,079
OBECHE	113.20	17,389
AFARA	114.20	18,013
AYO	114.10	19,026
OBOBO	119.80	19,041

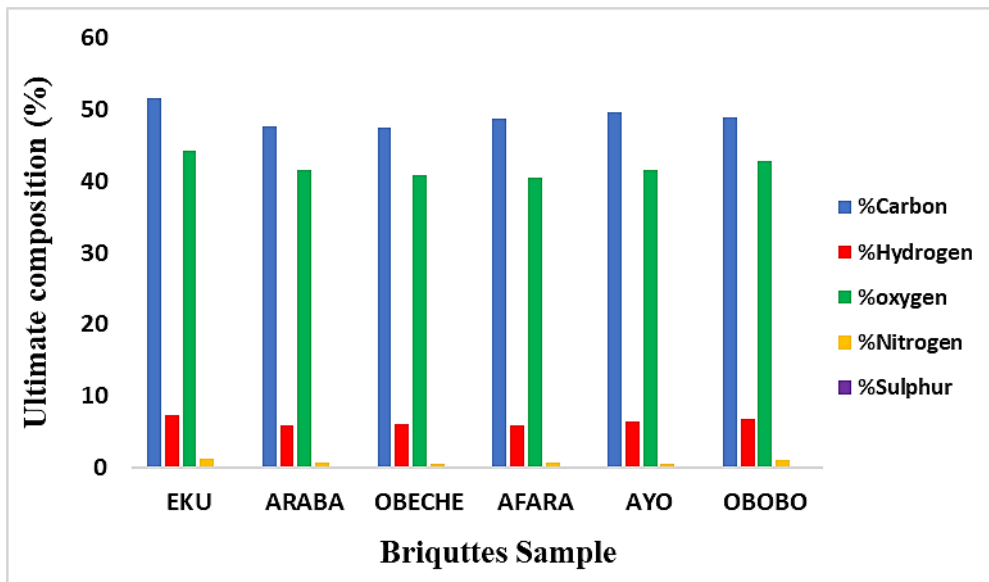

Figure 4: Ultimate composition of the briquette

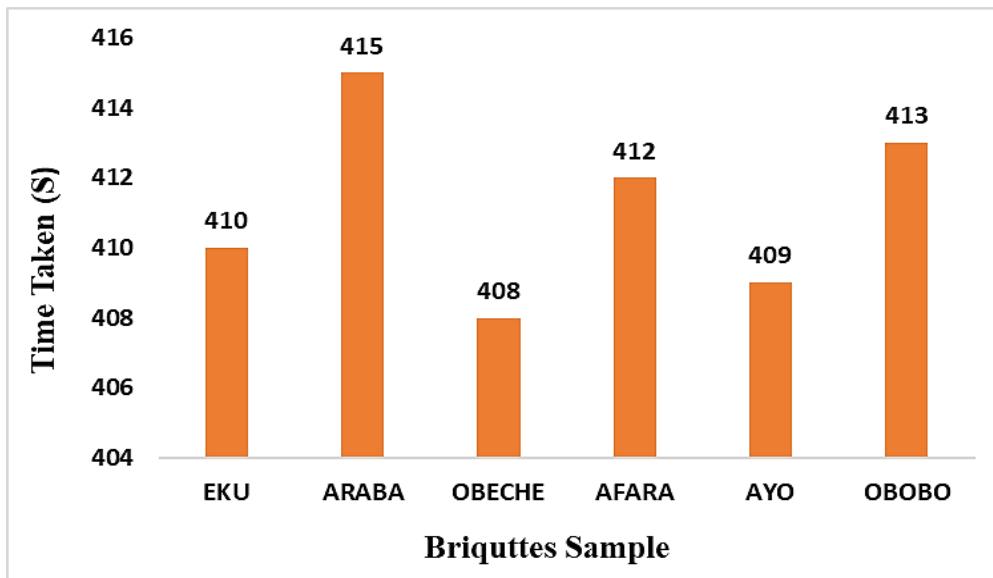

Figure 5: Showing the afterglow time of the briquette

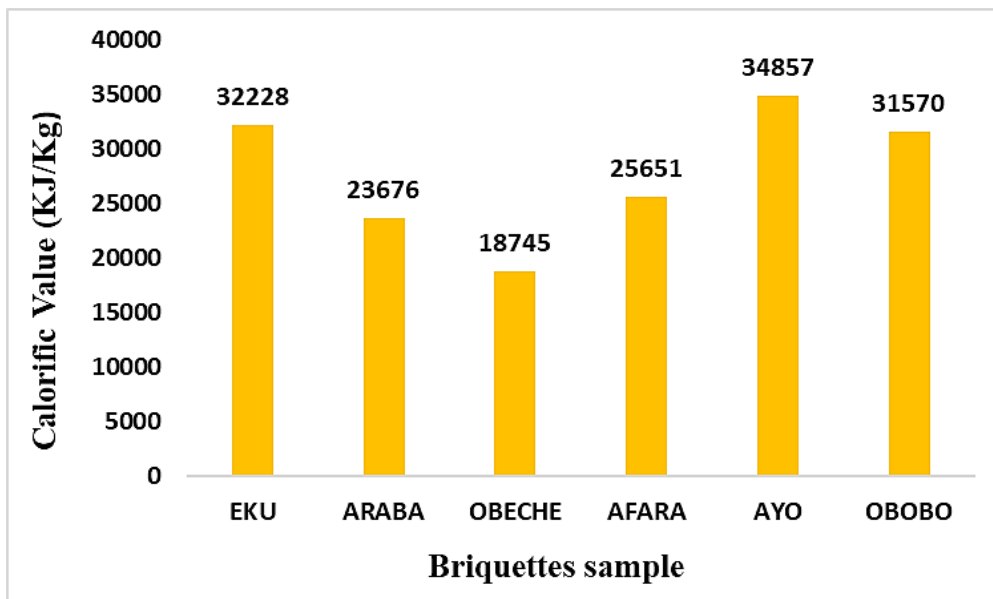

Figure 6: Calorific value of briquettes

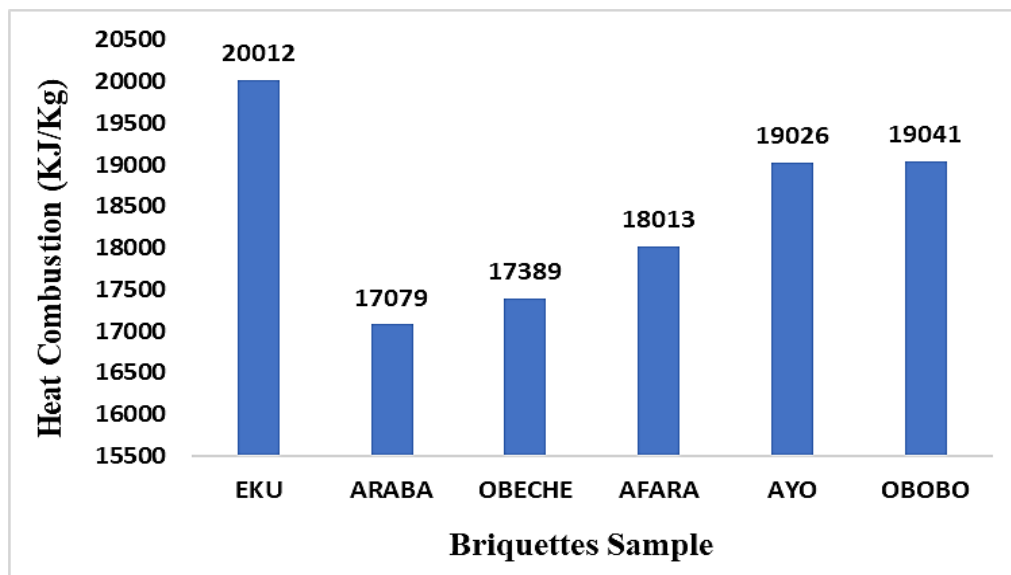

Figure 7: Result of heat combustion value of briquettes

#### 4. Conclusion

This research addresses the technical aspects of briquette combustion and emphasizes the potential socio-economic and environmental benefits of adopting such alternative fuels. This study's outcomes can guide future initiatives in the quest for cleaner and more sustainable energy practices in Nigeria, aligning with global efforts to mitigate the impact of traditional biomass consumption on the environment and public health. The experimental analysis of briquettes made from different wood types in Nigeria revealed some significant characteristics. Briquettes made from Eku wood had the highest heating combustion value of 20,012 kJ/kg, while Ayo has a calorific value of 34,857 KJ/Kg, followed by Afara and Araba. Overall, the findings suggest that the composition and density of wood significantly impact the thermal efficiency and performance of briquettes. This highlights the importance of carefully selecting wood types and quality control during production to ensure optimal performance of the briquettes.

#### Acknowledgment

This research was a labor of love, made possible by the hard work and dedication of the authors, as well as the support of our friends and families. We want to express our gratitude to everyone who made this research possible, including those who provided encouragement and support.

#### Author contributions

Conceptualization, O. Alabi. T. Adeyi and S. Ekun; methodology, T. Adeyi; validation, S. Ekun; investigation O. Alabi; writing—original draft preparation, O. Alabi; writing—review and editing, O. Alabi. T. Adeyi and S. Ekun; visualization, T. Adeyi; supervision, S. Ekun. All authors have read and agreed to the published version of the manuscript.

#### Funding

This research received no specific grant from any funding agency in the public, commercial, or not-for-profit sectors.

#### Data availability statement

The data that support the findings of this study are available on request from the corresponding author.

#### Conflicts of interest

The authors declare that they have no conflicts of interest concerning the publication of this paper.

#### References

- [1] E. Carter et al., Development of renewable, densified biomass for household energy in China, *Energy Sustain. Dev.*, 46 (2018) 42–52. <https://doi.org/10.1016%2Fj.esd.2018.06.004>
- [2] M. Puig-Arnavat, L. Shang, Z. Sárossy, J. Ahrenfeldt, and U. B. Henriksen, From a single pellet press to a bench scale pellet mill - Pelletizing six different biomass feedstocks, *Fuel Process. Technol.*, 142 (2016) 27–33. <https://doi.org/10.1016/j.fuproc.2015.09.022>

- [3] O. O. Alabi, O. J. Gbadeyan, A. Bala, G. O. Ogunsiji, and N. Deenadayalu, Study of Combustion Characteristics of Diesel-Vegetable Oil Blends Utilizing an Industrial Fuel Burner, *Fuel Commun.*, 18 (2023) 100104. <https://doi.org/10.1016/j.jfueco.2023.100104>
- [4] O. A. Akogun, M. A. Waheed, and S. Olasunkanmi, Physical and Combustion Indices of Thermally Treated Cornhusk and Sawdust Briquettes for Heating Applications in Nigeria, *J. Nat. Fibers*, 19 (2022) 1201-1216 . <https://doi.org/10.1080/15440478.2020.1764445>
- [5] J. L. Chukwunke, A. C. Umeji, E. N. Obika, and O. B. Fakiyesi, Optimisation of Composite Briquette Made From Sawdust / Rice Husk Using Starch and Clay Binder, *Int. J. Integr. Eng.*, 4 (2021) 208–216. <http://dx.doi.org/10.30880/ijie.2021.13.04.019>
- [6] O. O. Alabi and T. A. Adeyi, Analyzing Energy Performance and Assessing Dry Moisture Content of Briquettes through Numerical Investigations, *Eng. Technol. J.*, 42 (2024) 173-182. <http://dx.doi.org/10.30684/etj.2023.143782.1608>
- [7] O. O. Alabi, G. O. Ogunsiji, and S. A. Dada, Performances evaluation of blended alternative refrigerant in vapour compression refrigeration system., *Fed. Trend Sci. Technol. J.*, 8 (2023) 228–234.
- [8] A. O. Adeaga, O. O. Alabi, and S. A. Akintola, Experimental investigation of the potential of liquified petroleum gas in vapour compression refrigeration system., *LAUTECH J. Eng. Technol.*, 17 (2023) 1–7.
- [9] S. K. Sansaniwal, M. A. Rosen, and S. K. Tyagi, Global challenges in the sustainable development of biomass gasification: An overview, *Renew. Sustain. Energy Rev.*, 80 (2017) 23–43. <https://doi.org/10.1016/j.rser.2017.05.215>
- [10] O. A. Sotannde, A. O. Oluyeye, and G. B. Abah, Physical and combustion properties of charcoal briquettes from neem wood residues, *Int. Agrophys.*, 24 (2010) 189–194.
- [11] I. E. Onukak, I. A. Mohammed-dabo, A. O. Ameh, S. I. R. O. Id, and O. O. Fasanya, Production and Characterization of Biomass Briquettes from Tannery Solid Waste, *Recycling*, 2 (2017) 17. <https://doi.org/10.3390/recycling2040017>
- [12] O. A. Oyelaran, B. O. Bolaji, M. A. Waheed, and M. F. Adekunle, An experimental study of the combustion characteristics of groundnut shell and waste paper admixture briquettes, *KKU Eng. J.*, 42 (2015) 283–286. [https://doi.nrct.go.th/ListDoi/listDetail?Resolve\\_DOI=10.14456/kkuenj.2015.32](https://doi.nrct.go.th/ListDoi/listDetail?Resolve_DOI=10.14456/kkuenj.2015.32)
- [13] J. T. Oladeji, Comparative Study of Briquetting of Few Selected Agro-Residues Commonly Found in Nigeria, *Agric. Food Sci.*, 13 (2012) 80–86.
- [14] E. T. Tembe, E. Azeh, and D. O. Ekhuemelo, Effect of Particle Size on Quality of Briquettes Produced from Sawdust of *Daniella oliveiri* and *Gmelina arborea* in Makurdi , Benue State , Nigeria, *Asian Res. J. Agric.*, 3 (2017) 1–7. <http://dx.doi.org/10.9734/ARJA/2017/32079>
- [15] J. L. Chukwunke, A. C. Umeji, J. E. Sinebe, and O. B. Fakiyesi, Optimization of Composition of Selected Biomass for Briquette Production, *Univers. J. Mech. Eng.*, 8 (2020) 227–236. <http://dx.doi.org/10.13189/ujme.2020.080408>
- [16] O. O. Mong, O. E. Obi, C. E. Onyeocha, C. O. Ndubuisi, D. V Gaven, and V. Nnadiogbulam, An Experimental Study on Biomass Fuel Briquettes ' Quality as a Product of Waste Conversion in Nekede , Owerri , Nigeria, *J. Energy Res. Rev.*, 14 (2023) 22–31. <https://doi.org/10.9734/jenrr/2023/v14i4290>