



Enhancing performance of Double-Slope solar stills through optimization of heat addition methods: a comprehensive analysis



Mariam E. Murad^{a*}, Wissam H. Alawee^b , Hayder A. Dhahad^a , Z.M. Omara^c

^a Mechanical Engineering Dept., University of Technology-Iraq, Alsina'a street, 10066 Baghdad, Iraq.

^b Control and Systems Engineering Dept., University of Technology-Iraq, Alsina'a street, 10066 Baghdad, Iraq.

^c Mechanical Engineering Dept., Faculty of Engineering, Kafrelsheikh University, Kafrelsheikh, Egypt.

*Corresponding author Email: me.21.14@grad.uotechnology.edu.iq

HIGHLIGHTS

- Enhanced modifications were made to double-slope solar stills to raise water output significantly.
- Solar stills are suitable for various climates, including hot and humid ones.
- Thermoelectric modules led to 1032.5 L/m².year water production increase.
- Evacuated Tube Collectors (ETCs) and multi-scale heat exchangers substantially improved efficiency.

ABSTRACT

This comprehensive research paper reviews the latest techniques to enhance the productivity of double-slope solar stills by providing quantitative data on key research outcomes. With the global water scarcity crisis and the need for effective desalination technology, this study focuses on solar-based desalination techniques and their specific application in double-slope solar stills. This paper offers a comprehensive and quantitative analysis of heat addition methods in double-slope solar stills by examining published research findings, providing valuable insights for researchers and practitioners. The study reveals significant improvements in productivity through various modifications. Evaporation enhancement, heat transfer enhancement, and condensation enhancement have proven to be highly effective, resulting in substantial increases in water production. The use of thermoelectric modules in double-slope solar stills has shown a remarkable 250% increase in water production by heating the water in the basin, which enhances evaporation rates and condensation on the glass cover. Moreover, the integration of Evacuated Tube Collectors (ETCs) has demonstrated a notable improvement in double-slope solar stills' life cycle conversion efficiency. The system incorporating ETCs achieved an impressive 59.42% higher efficiency than a system without ETCs, primarily due to the enhanced thermal input provided by ETCs to the solar still's basin. Another significant finding is the six-fold increase in water production achieved by implementing the double-slope solar still with a PV heater (CSSPVH) compared to conventional solar stills (CSS). This substantial improvement positions the CSSPVH design as a highly efficient solution for long-term potable water generation. Furthermore, adding a water heater to the base tank of a solar still has been found to raise water temperature quickly, resulting in a significant boost in production by approximately 370%. However, it is important to note that productivity decreases with increasing wind speed. Even with an outer cooling fan to cool the solar still's glass surface, productivity is reduced by 4% and 8% for wind speeds of 7 m/s and 9 m/s, respectively.

ARTICLE INFO

Handling editor: Mohammed A. Fayad

Keywords:

Modified double slope solar still
Heat addition techniques
Sustainable water solutions
Productivity enhancement
Water heater
Heat exchangers

1. Introduction

Water and electricity are the greatest critical demands on the planet, and finding alternate supplies is the most difficult [1-3]. Demand for water and energy has constantly increased due to expanding populations and rapid advancement in numerous spheres such as hydropower, transportation, industries, building sectors, irrigation operations, air conditioning due to climate change, and so on [4-6]. Freshwater scarcity is a major issue, particularly for individuals living in saline water and arid locations [7-10]. Cities located near coastal areas and arid regions face the challenge of limited access to freshwater for drinking and other essential purposes [11-14]. Even though water covers a significant portion, approximately 71%, of the Earth's surface, the majority, around 97%, exists in the form of saltwater in seas and oceans [15-17]. Another 2% is locked in Polar Regions as ice, leaving only 1% available as freshwater in lakes, rivers, and groundwater. In addition, it is approximated that each year, around

3.575 million people lose their lives due to diseases caused by water-related problems[18-21]. These issues encompass the scarcity of safe and drinkable water and the pollution of water sources resulting from the release of untreated wastewater into the environment [22-26]. This pollution adversely affects rivers, lakes, oceans, and other contributing factors[27,28]. Studies suggest that the world will face a water deficit of approximately 60% by 2025, primarily due to the increasing global population [29-33]. The World Health Organization has also highlighted that by 2050, over 50% of the world's freshwater demand is expected to be met [34-38]. To address this challenge, several techniques and devices have been developed to convert saltwater into drinkable water [39]. These include reverse osmosis, multi-stage flash, electrodialysis, humidification-dehumidification, and solar stills [40-42]. Distillation, an age-old method for obtaining freshwater from brackish water, falls short of meeting the growing freshwater demands of the population [43,44]. As a result, researchers have been compelled to explore alternative methods to enhance desalination systems and meet the required freshwater needs. Desalination processes, while effective, rely on high-energy resources. However, utilizing fossil fuels as an energy source is undesirable due to the environmental pollution caused by their emissions, which can contaminate water sources. In contrast, solar energy emerges as a promising solution [45,46]. It is a renewable, freely available resource abundant in regions with high solar intensity. Solar energy provides a clean and environmentally friendly alternative to meet the energy requirements of desalination processes and compensate for the limitations of traditional energy sources [47-49]. There are two main types of desalination technology processes: thermal processes, which involve power and heat [50,51], and membrane technologies, which rely solely on electricity. According to the latest statistics from the International Desalination Association, the installed capacity of various desalination processes can be categorized as follows: Reverse osmosis (RO), a membrane process, represents approximately 65% of the total; thermal multi-stage flash (MSF) processes make up 21%; multi-effect distillation (MED) contributes 7%; electro-dialysis and electro-dialysis/reversal (ED/EDR) provides 3%; nano-filtration accounts for 2%; and the remaining 2% is attributed to other processes [52-54], as depicted in Figure 1.

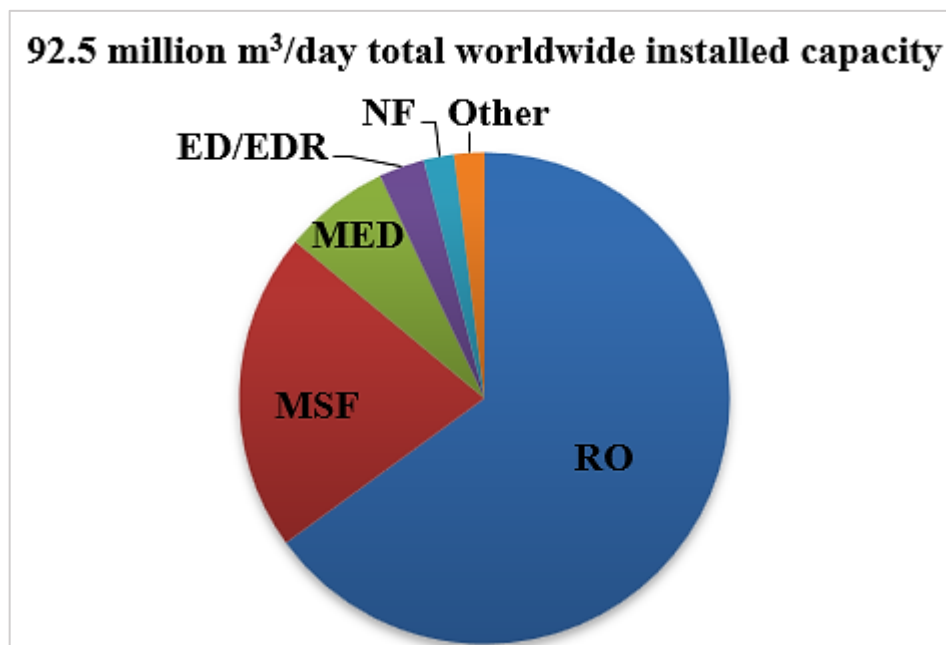

Figure 1: The installed capacity of reverse osmosis (RO) and thermal desalination processes

This work is notable progress because of its comprehensive analysis and thorough investigation of various heat addition strategies used in double-slope solar stills. The research thoroughly analyzes the fundamental concepts, benefits, drawbacks, current advancements, and resulting effects on double-slope solar stills' overall effectiveness and performance. This research goes beyond previous studies by thoroughly summarizing and comparing the data on heat addition strategies in solar stills. The result is a detailed and insightful understanding of the issue, offering valuable perspectives on the most effective and efficient methods to improve the performance of double-slope solar stills. This article presents a pioneering investigation on the techniques employed to introduce heat into double-slope solar stills. We focus on analyzing heat addition techniques in double-slope sun stills instead of investigating many elements of solar stills and methods for improving their performance, which previous studies have done.

In order to bridge this existing knowledge deficit, this study aims to conduct an exhaustive examination and comparative assessment of heat addition techniques utilized in double-slope solar stills. By synthesizing existing research findings, we aim to provide novel insights into these strategies' operational principles, benefits, limits, recent progress, and resulting performance effects.

Despite efforts to conduct a comprehensive and objective evaluation, this study may have certain limits. The dependability and consistency of the data reported in the chosen research are significant. Variations in experimental designs, measuring methodologies, and reporting requirements among researchers may hinder meaningful comparison and generalization of results. This review largely focuses on double-slope solar stills and related heat addition techniques. Therefore, the findings may not

apply to different solar stills or desalination systems. Figure 2 depicts the research purpose and scope, including all investigation stages.

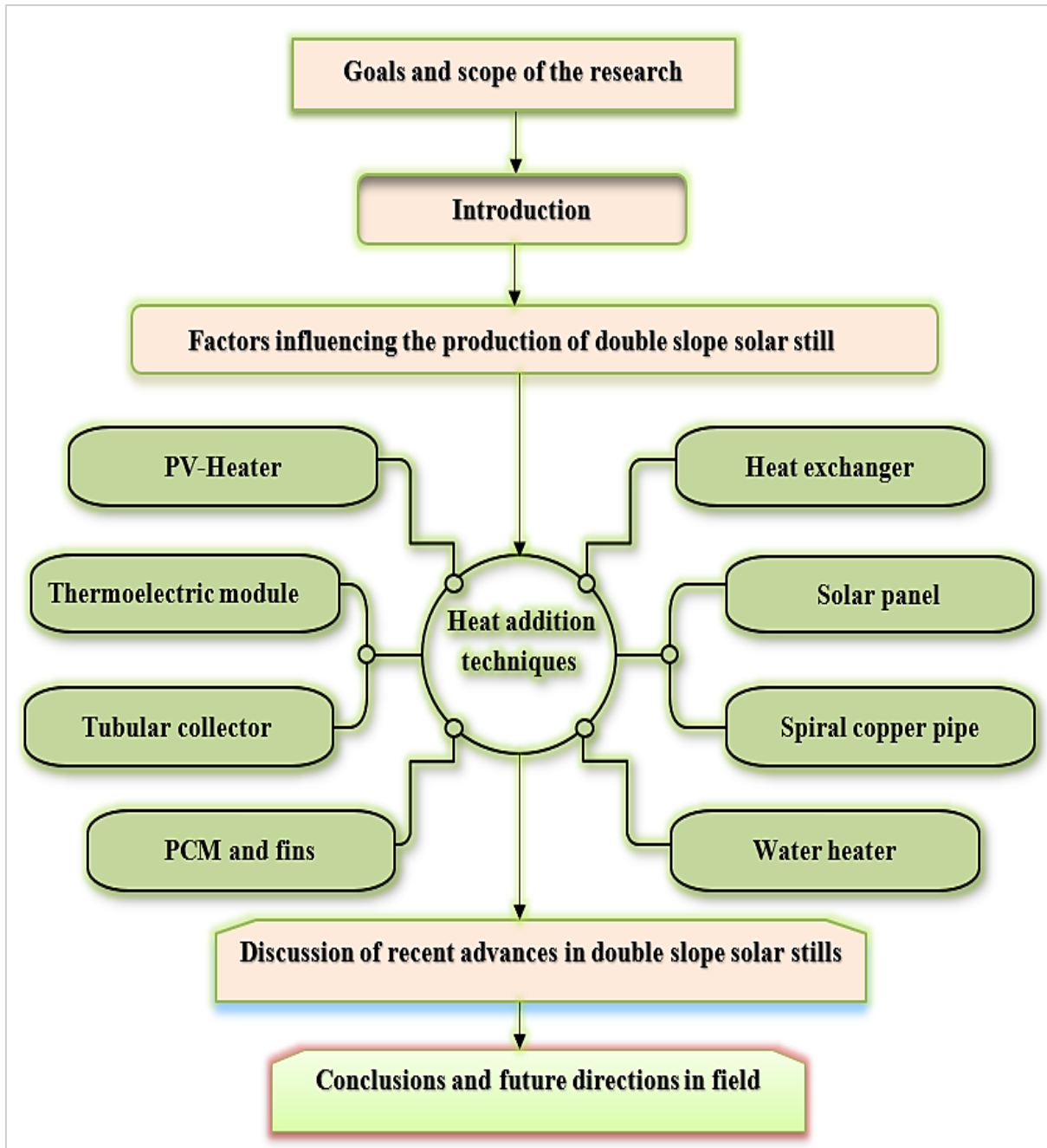

Figure 2: Workflow diagram of the current study

2. Factors influencing the production of double-slope solar still

Several factors influence the production of double-slope solar still. These factors play a crucial role in determining the efficiency and output of the solar stills. The productivity of a solar panel is still influenced by three factors, namely ambient, operating, and design conditions [55-59], shown in Figure 3. Various ambient factors, such as solar radiation, ambient temperature, relative humidity, wind velocity, cloud cover, and particulate presence [23,60,61], affect the productivity of a solar still. Unfortunately, these environmental factors are beyond human control and directly affect the solar still's performance [62,63]. There are, however, design and operational parameters that can be readily adjusted to boost productivity. By optimizing these controllable parameters, such as the design of the solar still and its operational settings, its performance and productivity can be enhanced. While we cannot control environmental factors, we can maximize the efficacy and output of the solar still by making adjustments within our control [64-67].

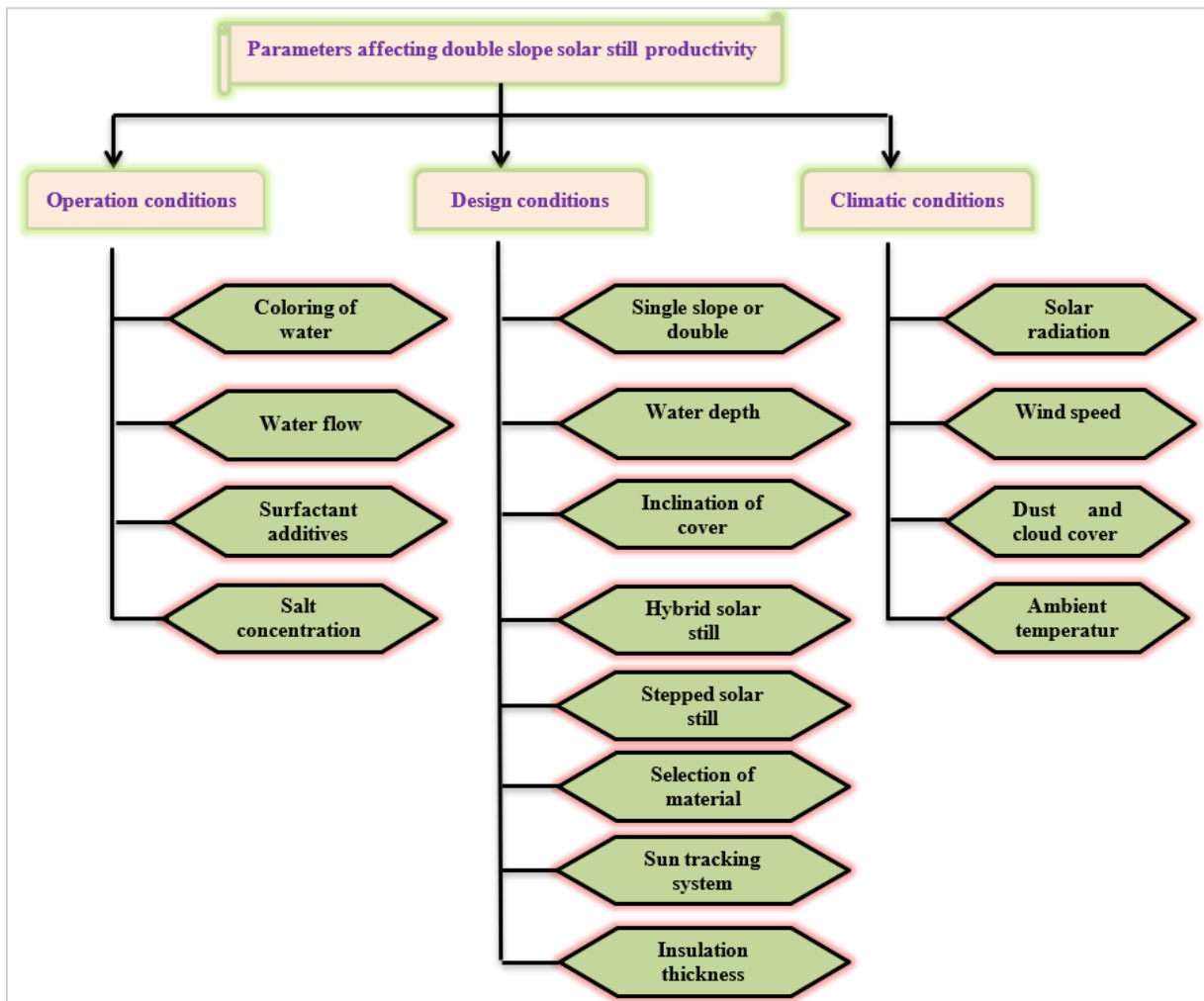

Figure 3: Factors influencing the production of basin-type solar still

3. Heat addition techniques in double slope solar still

Double slope solar stills are advanced solar still designs that employ two glass covers to maximize heat retention and enhance the efficiency of the distillation process. The performance of these solar stills is significantly impacted by the methodology employed for heat addition. Heat addition methods can be either passive or active. Passive approaches use natural phenomena like conduction, convection, and radiation to transport heat into the brine. Active approaches use external heat sources, including solar collectors, thermoelectric modules, and PV heaters, to improve heat transfer to the brine. Several heat addition strategies may be used in double-slope solar stills. Among the most widely used active approaches are:

3.1 Double-slope solar still with evacuated tubular collector (ETC)

The evacuated tubular collector, which uses a vacuum layer between two glass tubes, is a breakthrough in solar thermal collection. This design reduces convective heat transmission, preventing heat loss. Consequently, a significant amount of heat is introduced into the collection area of the solar stills. Singh and Tiwari [68] developed a characteristic equation for a solar-powered water purification system with a double slope design, employing N evacuated tube collectors. Their study concluded that employing N evacuated tubular collectors in a double slope water purifier system, which operates on solar energy, leads to higher daily energy efficiency than similar configurations. Along with this, Sharma et al. [69] performed a theoretical study based on energy metrics and efficiency for the climate of New Delhi of the double-slope solar distiller unit supplemented with N identical parabolic concentrator integrated with evacuated tubular collectors (NPCETCDS), as shown in Figure 4. Eight collectors and a fluid mass flow rate of 0.012 kg/s were used in the computation. In terms of the number of collectors, basin size, fluid mass flow per unit time, and identical weather, the results of the NPCETCDS have been compared to those of the double-slope solar distiller unit supplemented with N identical evacuated tube collectors (NETCDS). The findings indicate that when comparing NPCETCDS and NETCDS with the same number of collectors, the former has a lower energy payback time of 88.50%, a higher life cycle conversion efficiency of 51.93%, and a higher daily exergy efficiency of 78.01%.

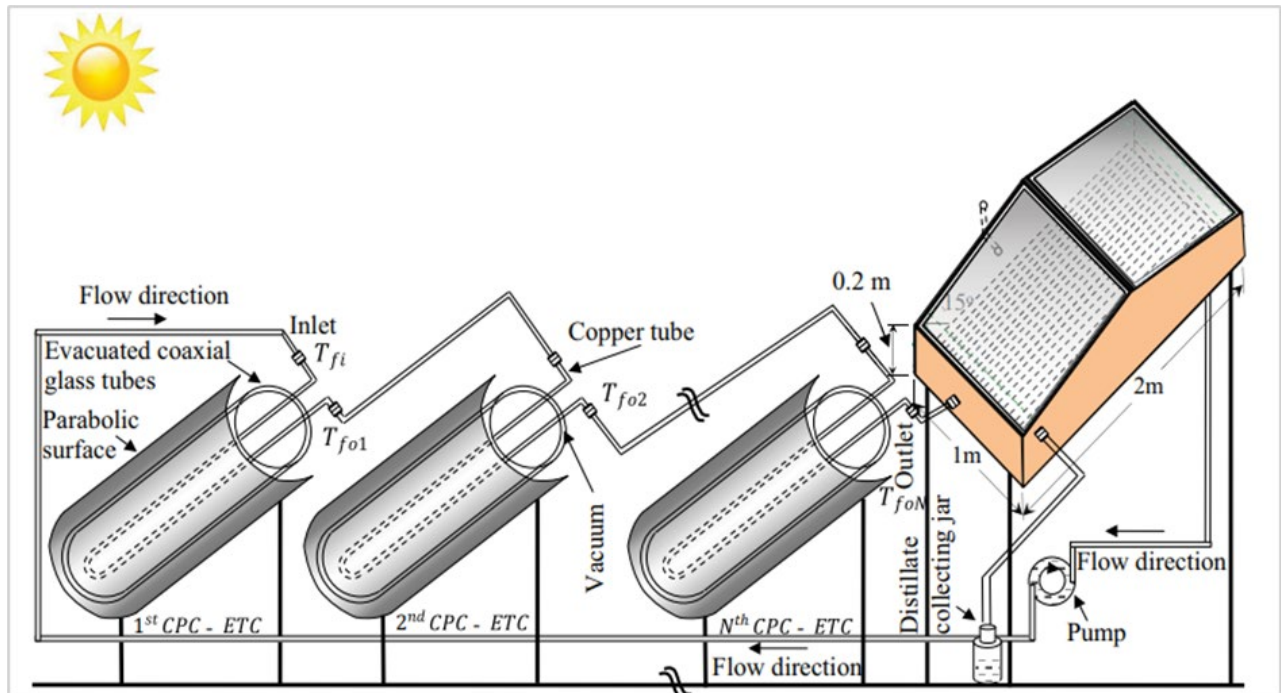

Figure 4: Schematic diagram of NPCETCDS [69]

In another study, Bait [70] studied the application of a tubular solar collector-assisted double-slope solar still to desalinate saline water. The analysis encompassed an evaluation of the exergy performance, enviro-economic aspects, and economic viability of the subject under investigation, followed by a comparative assessment against a solar still of comparable dimensions. According to the results, the traditional and modified solar stills were found to have an estimated annual yield of around 405.04 and 549.77 kg/m², respectively. The passive system's hourly exergy efficiency and global exergy efficiency were around 7% and 30%, respectively, while for the active system, they were approximately 11% and 41%. The economic research demonstrated that the production cost of distilled water was comparatively lower for the simple solar still (approximately 0.018 \$/L) compared to the improved still (approximately 0.03 \$/L) at an interest rate of 5% and a lifetime of 30 years. The environmental cost parameter (ZCO₂) for the active solar unit was calculated to be approximately 4.42 \$/year based on exergy.

3.2 Double-slope solar still with thermoelectric modules

Devices that convert heat to electricity and vice versa are known as thermoelectric modules. They can heat water in a solar still, which can help improve the still's productivity [71]. Applying thermoelectric heating and cooling technologies improves the thermal gradient between water and glass. The implementation of a thermoelectric heat source increases the temperature of water. It accelerates its evaporation rate, while implementing a thermoelectric cooling source decreases the temperatures of the glass surface and the region where condensation occurs. The operation of the thermoelectric unit can be achieved using solar panels.

In a study conducted by Shoeibi et al. [72], the effect of simultaneous convection heating and cooling on the efficiency of double-slope solar still in Tehran and the specific climate of Iran was investigated. The high-temperature side of the thermoelectric module is attached to the device's Hot water tank and sent through a heat exchanger to a solar still, where it is circulated. The water flowed across the glass's surface because the thermoelectric device's cold side's cooling effect lowered the water's temperature. The data showed that the modified solar still produced approximately 1032.5 liters of water per square meter annually at a cost of \$0.1055 per liter. Compared to conventional solar stills, the former produce approximately 448.9 liters of water per square meter annually, costing 0.1763 dollars per liter. Dehghan et al. [73] investigated how the cold side effects of a thermoelectric module affected a double-slope solar still's output rate, as depicted in Figure 5. The outcomes on the other side of the glass were compared and contrasted with those of three thermoelectric modules installed on one side. Although the experimental findings demonstrated a 3.2-fold increase in the output rate of the thermoelectric modules, the thermoelectric area was approximately 2.8 times smaller than that of the glass component. It turns out that the temperature differential between water and the thermoelectric module is greater than between water and glass, which means that condensation and production rates are larger in the former case.

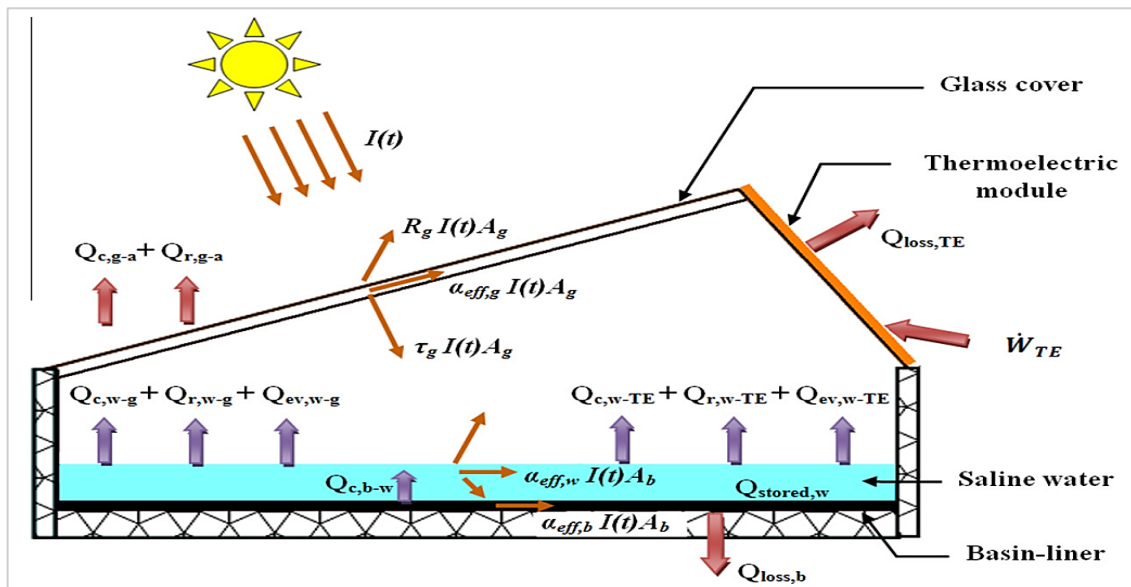

Figure 5: Solar still integrated with a thermoelectric module [73]

Additionally, Rahbar et al. [74] investigated the exergy of a double-slope solar still with thermoelectric heating modules. The results suggest that using thermoelectric modules as water warmers increases the temperature of the water and thus enhances the efficiency of the solar still. The increase in temperature of the heatsink and the resulting heating caused by the functioning of the thermoelectric modules help to reduce the decrease in water output throughout the afternoon when solar intensity decreases. The system's exergy efficiency exhibits an upward trend throughout the conducted experiments, reaching its peak value of roughly 25% at 3 p.m. Krishna et al. [75] used thermal modeling and experimental validation to study the double-slope passive solar still (DSPSS). Active (integrated with a disc-type concentrator and photovoltaic module) and passive solar stills were compared, utilizing advanced thermal modeling to make design suggestions. Active solar stills perform 21.71% better than passive solar stills (PSS), with 17.5% thermal efficiency. Active solar still has 3.5% exergy efficiency, whereas passive solar has 2.4%. To find the highest effective solar concentrating disc diameter, 0.5 to 2 meters were optimized. Furthermore, the solar concentrating disc diameter was optimized for diameters of 0.5, 1, 1.5, and 2 meters. The predicted yield and maximum water temperature were 2.83, 3.64, 5.1, and 7.3 kg/m² and 70.02, 75.8, 85.2, and 98.2°C, respectively.

3.3 Double slope solar still coupled with PV-Heater

Riahi et al. [76] assessed the efficiency of a double-slope solar with a 500 W heater. Six solar panels attached to four batteries powered the heater, tested in Malaysia for days. The solar still basin used a black-coated steel trough. The solar still basin was constructed using a black-coated steel trough. A study found that a double-slope solar with photovoltaic modules outperformed a regular solar still, yielding almost six times more water. Furthermore, the water generated by solar stills meets the drinking water criteria set by the World Health Organization (WHO).

Below are the many benefits of utilizing a solar still equipped with a photovoltaic (PV) heater:

3.3.1 Enhanced efficiency

The PV heater can supply extra heat to facilitate water evaporation in the basin, resulting in a substantial boost in production.

3.3.2 Nighttime operation

When there is no solar radiation at night, the solar still may be powered by the PV heater. This might improve the system's overall productivity.

3.3.3 Dependability

For areas with limited access to water, the solar still with a photovoltaic heater is a reliable option. Both low levels of solar energy and cloud cover do not affect it.

3.3.4 Economic efficiency

A technology that provides a high degree of cost-effectiveness in generating drinking water is the solar still fitted with a photovoltaic heater. The system's costs can be balanced by the decrease in water usage.

3.4 Double slope solar still with an immersion water heater

Al-Qarni [77] increased the production of a double-slope solar still by utilizing an immersion water heater. The effectiveness of employing an external fan to cool the glass surface is also investigated. Experiments were conducted over the winter season

in Saudi Arabian climatic conditions at latitude 26 degrees north. Our study uses a solar still with a glass slope angle of 35 degrees. Because the solar output is still higher at lower water depths, the water level in the base tank was kept at 1 cm. The trial findings revealed that using two water heaters with 500 W capacity enhanced production by 370%. When an external cooling fan was employed, productivity decreased by 4% and 8% at wind speeds of 7 and 9 m/s, respectively. Thermal modeling was also performed utilizing the heat and mass transport relations, and numerical simulations were run to confirm the experimental results.

Al-Hamadani and Yaseen [78] used an immersion model DC water heater to increase the production of the solar still's fresh water. They also examined the impact of using an external fan to cool the glass surface. The experiment was conducted in Iraq during the summer at a latitude of 33.2 °N. This experiment selects a solar still with a glass slope angle of 32.5°. The water level in the bottom basin is kept at 3 cm since solar still produces more at low water depths. According to the testing results, using DC water heaters with 350 W of capacity each significantly boosted freshwater production by 370%. Fresh water production decreased by 7% and 15%, respectively, when an external cooling fan was utilized at wind speeds of 7 m/s and 9 m/s. A thorough comparison with previous experimental studies was conducted (refer to Figure 6).

In addition to this, Bait et al. [79] integrated a double-slope solar still with a cylindrical solar water heater, driven by two primary motivations. Firstly, the aim is to elevate the water temperature within the solar still to enhance its production capacity significantly. Additionally, the cylindrical solar heater is known for its efficient water heating capabilities with minimal heat losses to the surroundings. Combining these two systems results in active solar still. The outcomes clearly demonstrate a significant rise in distillate mass production and temperature when utilizing the active solar still. The temperature rises by 8.94 °C, while the distillate mass production improves by 0.67 kg/m²/day.

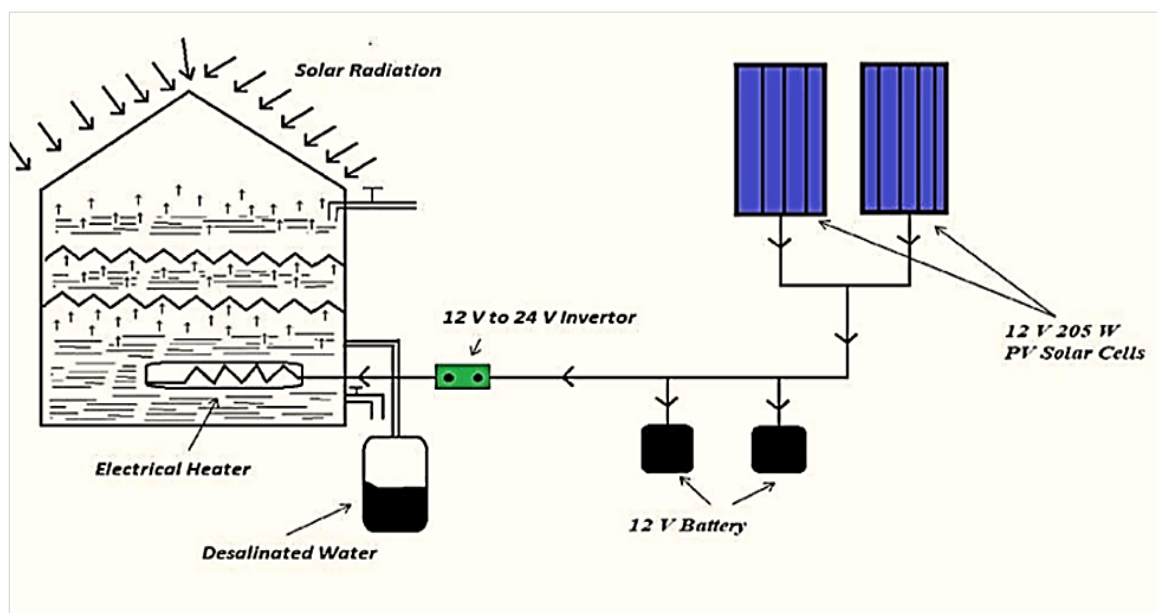

Figure 6: Solar still integrated with an electrical heater [78]

3.5 Double slope solar still coupled with water heater and PCM

Another experimental study was undertaken by Alawee et al. [80] in Baghdad, Iraq, to enhance the efficiency of a conventional solar still. This was achieved by the implementation of three concurrent approaches. The use of internal reflecting panels in the solar still design resulted in an 18.5% increase in the production of distilled water. In addition, the combination of a solar still and a collector/storage solar water heater, combined with the use of gravel as a thermal energy storage medium, substantially increased productivity by 48.0%. The study findings revealed that increasing the mass flow rate of salt water enhances freshwater production and energy efficiency. Consult Figure 7.

Dhivagar et al. [81] investigated the viability of solar desalination by utilizing black powder-coated crushed granite stone, assessing its energetic, energetic, and economic dimensions. The stone bed serves to preheat water for the solar still. Furthermore, the system is integrated with a district heating network to fulfill desalination requirements even during periods of low solar activity or high demand. The energy and exergy efficiencies were improved, reaching 15.7% and 27.2%, respectively, at a depth of 1 cm. The integration with the district heating network significantly enhanced the system's capabilities. In the summer, the excess heat from the network greatly increased water production and reduced the temperature of the water that was being released. This resulted in an 182% increase in overall productivity at a depth of 3 cm. In addition, the system enhanced the district heating network by decreasing the return flow temperature by 3 °C, enhancing its cooling capacity. In a different approach, Hayek and Badran [82] compared the efficiencies of a double-slope basin solar still versus a single-slope basin solar still. Reflective surfaces covered all walls. In August experiments, researchers found that reflectors on the interior walls of the single slope basin solar still increased distilled water output by 20% compared to the double basin solar stills. The two stills showed that the water's surface temperature is related to incident solar energy and that reducing the water level and adding dye can boost production. Sonker et al. [83] conducted experimental and computational solar still simulations. The distillate has been enhanced

by storing PCMs (paraffin wax, stearic acid, and lauric acid) in a copper cylinder at varying water depths (1–5 cm), as seen in Figure 8.

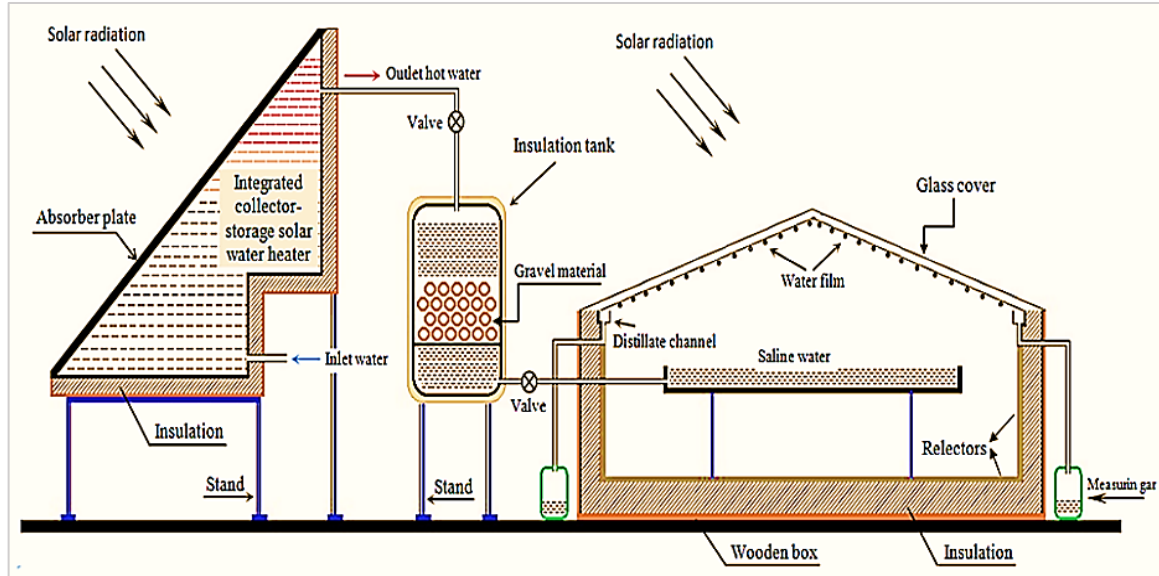

Figure 7: Modified solar still test [80]

Additionally, the highest output level has been achieved at a distance of 1 cm for all three PCMs. The maximum water basin temperature in paraffin wax has decreased by 9.2% compared to stearic acid (17.6%) and lauric acid (21.5%) when the water depth increased from 1 to 5 cm. The distillate yield of paraffin wax, stearic acid, and lauric acid held in a copper cylinder has grown by 1202, 1015, and 930 ml/m² day, respectively. El-Sebaey et al. [84] examined and contrasted the performance of double-slope solar stills (DSSS) and cylinder sector solar stills (CSSS) in a separate investigation. Experiments were carried out under the climatic conditions of Egypt, utilizing various materials and a water depth of 2 cm in the receptacle of the stills. According to the results, the overall productivities of DSSS and CSSS, using black dye and black fiber, were 3029 ml/m² and 3514 ml/m², respectively, under the same operating circumstances. Abdullah et al. [85] created modified solar stills (MSS) through experimentation to enhance the yield of drinking water. Internal reflectors (MSS-IR), Nanophase change material (MSS-IR-PCM), and spiral copper water heating coils (MSS) have all been used in testing the MSS. The increases in thermal efficiency and productivity for MSS, MSS-IR, and MSS-IR-PCM are 66%/44%, 81%/46.2%, and 115%/51.3%, in that order, as shown in Figure 9. Therefore, compared to the scenario without PCM, using PCM increased MSS-IR productivity by around 34%. Analysis of the economy was also taken into account. The cost of the distilled freshwater is 0.03 and 0.0235 \$/L for the CSS and MSS-IR-PCM, respectively.



Figure 8: Pictorial view of PCM-loaded copper cylinders [83]

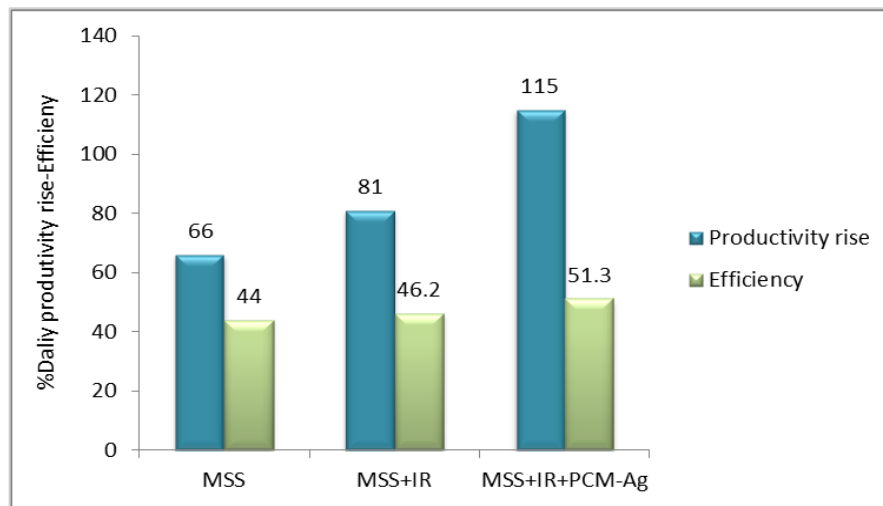

Figure 9: The productivity and thermal efficiency increase of the investigated solar stills [85]

Likewise, Afolabi et al. [86] undertook research to overcome the constraints of double-slope solar still by incorporating phase change material-thermal energy storage (PCM-TES) into the system. To do this, the phase change material (PCM) was encapsulated at a microscopic level utilizing vacuum molding processes in combination with an epoxy resin composite. Integration of TES with DSSS increases water production to 7.5 liters daily and extends operation by 3 hours. Condensation and evaporation rates increase by 105% with higher production. TES reduces heat losses, and a microencapsulated insulator prevents PCM leakage. Desalinated water from the system is free from metals, bacteria, and organic contaminants. Economic analysis shows a payback period of 0.8 years based on year-round operations. Findings align with existing models, and water quality meets WHO standards. Shajahan et al. [87] tested how well a double-slope solar distillation system worked and how much potable water it produced by mixing silver nanoparticles with phase change material (PCM). Introducing silver nanoparticles into the phase change material (PCM) diminishes the productivity and effectiveness of the solar still during the charging phase. However, using the stored latent heat in the PCM enables the still to provide drinkable water even after sunset. The findings indicate that the phase change material (PCM) has a greater ability to store heat, while the silver nanoparticles have a stronger ability to transport heat. Consequently, there was a 16% increase in the amount of drinking water produced and a 62.53% improvement in the thermal efficiency of the double-slope solar still. The price per liter of drinkable water produced by the solar still has decreased to 3.80 INR, and the time it takes to recover the initial investment is 2 years, which may be further shortened by using phase change materials (PCM) and nano-enhanced PCM within the solar still.

3.6 Double-slope solar still integrated with combined fins, water heater, and wick materials

Samuel et al. [88] developed and constructed an efficient solar still specifically designed for isolated islands with limited freshwater sources but abundant solar irradiance. The solar still combines a conventional passive double-slope design with additional features such as water heater, fins, and wick material to enhance heat transfer and evaporative surface area. Experimental tests were conducted, and the results showed that the augmented solar still significantly increased the distillate output compared to the conventional passive design. The average daily and daytime hourly productivity improved by 147% and 245%, respectively. Based on the tested design, the active solar still could produce 4.4 liters of drinkable water per day. Alawee et al. [89] tested a cords-wick double slope distiller in various situations. It compares cord counts (9,16, 25, and 35) with WDSSS reflectors and condensation cycles. The results show that 25 and 35 cords provide the best WDSSS performance with and without reflectors and condensation cycles. At the 25-cord configuration, the WDSSS without reflectors or a condensation cycle yielded 140% more than a standard solar still (7200 vs. 3000 mL/m².day). Additionally, the WDSSS with reflectors and 25 cables yielded 180% more than the traditional solar still (9500 vs. 3400 mL/m².day). Condensation and reflectors increased WDSSS production by 121% at 25 cords compared to the traditional solar still (11250 vs. 3600). Finally, reflectors and a condensation cycle with 35 jute strands gave the WDSSS its best performance, increasing efficiency by 51.5% and distillate production by 228%. Chaichan et al. [90] discussed the newest improvements and developments mentioned and highlighted in this report. The objective of all the examined research is to attain optimal productivity and efficiency, minimal capital expenses, and straightforward installation. The examined breakthroughs include phase change materials (PCMs), nanoparticles, and highly efficient solar reflectors. The evaluation of current changes in sun stills includes factors such as location, water temperature, solar radiation strength, production level, inclination angle, productivity, and efficiency, in addition to the existing features of solar stills. The performance characteristics of solar stills were also examined in relation to altering the absorption area and employing reflectors and condensers. Several enhancements were implemented, leading to elevated levels of production. The addition of a phase change material leads to a significant boost in the distiller's output, ranging from 10% to 180%. Adding a nanomaterial to paraffin still results in a productivity boost ranging from 25% to 320%. Moreover, Wicks enhances the productivity of the still by 20% to 300%, depending on its design. Pali et al. [91] increased the production of a basin-type double slope multi-wick solar still by adding wicks. The experimental results for several months are provided, and the influence of climatic and operational conditions on the performance of modified basin-type double slope multi-wick solar stills (MBDSMWSS) is investigated. The study was

done in India. Significant heat input, yield, and thermal efficiency improvements have been achieved. The instantaneous efficiency equation modifies the yield output and heat input to the solar still by taking into account input from both the glass covers and the transparent walls. The results reveal that the greatest production is 9012 ml/day (4.50 l/m² day) for black cotton wick compared to 7040 ml/day (3.52 l/m² day) for jute wick at 2 cm water depth in MBDSMWSS. Furthermore, given the same basin conditions, the total thermal efficiency of MBDSMWSS with jute and black cotton wicks is 20.94% and 23.03%, respectively. Figure 10 illustrates modified basin-type double slope multi-wick solar stills using different wick materials: (a) jute wick and (b) black cotton wick. Bhargva et al. [92] conducted an experimental investigation comparing the performance of two similar single-slope solar stills. One still incorporated rectangular aluminum fins and a bamboo cotton wick, while the other served as a traditional solar still. The performance of both stills was compared at varying water depths of 1 cm, 2 cm, and 3 cm. The experiments revealed that optimal production and temperature were achieved at a water depth of 1 cm. Additionally, introducing a bamboo cotton wick to the rectangular fins in the solar still basin led to an approximate 19% increase in daily production. The incorporation of rectangular aluminum fins in the solar still design resulted in an increased heat transfer area and basin water evaporation rate. Figure 11 in the study shows a solar still with rectangular aluminum fins covered by a bamboo cotton wick. It includes a photograph (a) of the wick-covered fins in the still basin, as well as the dimensions (b) of the rectangular fins used in the setup.

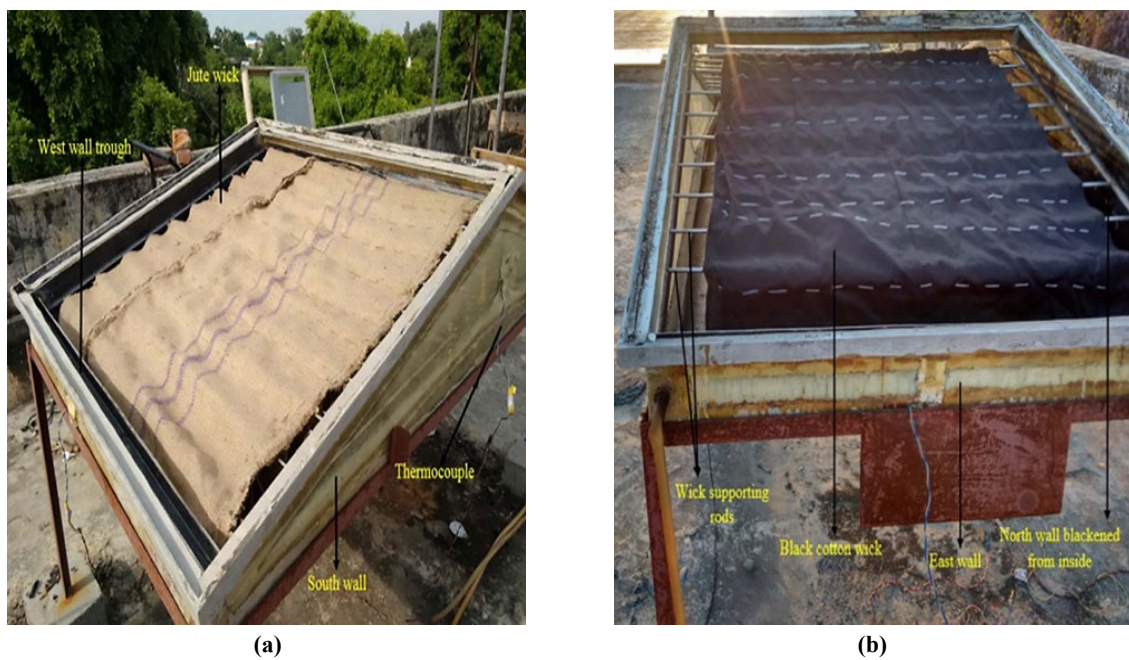

Figure 10: Photograph of modified basin-type double slope multi-wick solar stills using (a) jute wick and (b) black cotton wick [91]

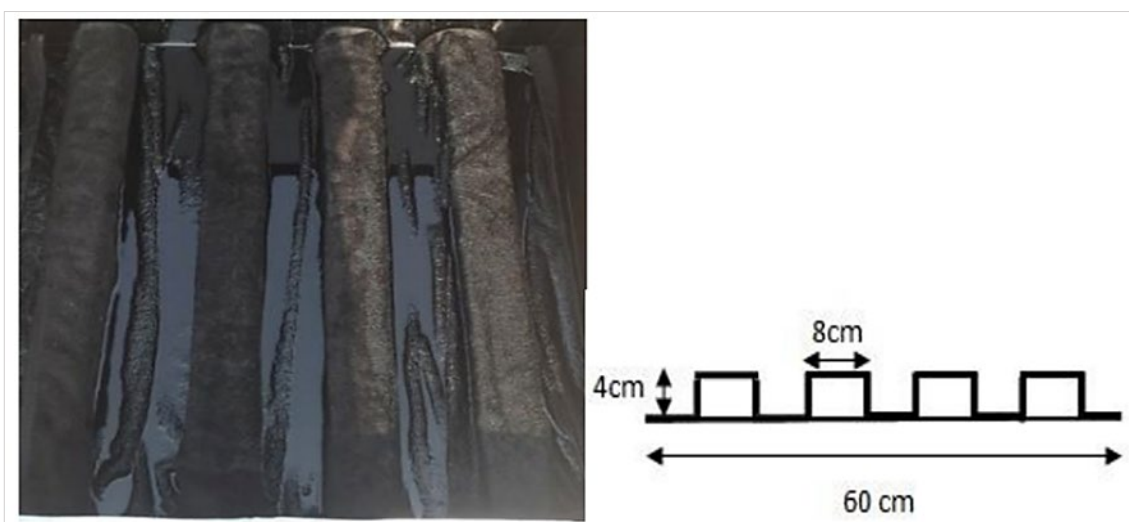

Figure 11: (a) Photograph of bamboo cotton wick-covered rectangular fins in the still basin; (b) rectangular fin dimensions [92]

3.7 Double slope solar still equipped with external spiral copper pipe

Al-Qadami et al. [93] looked at how well a double-slope solar still worked when connected to an outside spiral copper tube that heats water. They compared active and passive solar stills' yield and water quality indicators with equal evaporation areas. The experimental results revealed several important findings. Firstly, solar radiation intensities, water temperature, and ambient temperature strongly influenced the water production rates. Higher solar radiation and water temperatures resulted in increased water productivity. Secondly, the active solar still outperformed the passive one, with a 20% higher water productivity. The study highlights the potential of using solar stills for water desalination, as they demonstrated a positive relationship between water production and environmental conditions.

3.8 Double-slope solar still integrated with solar panel

Al-Qadami et al. [94] conducted a study to evaluate the productivity and efficiency of a standard double-slope solar system that incorporates a solar system. Two models, namely active and passive, were constructed using identical evaporation and condensation areas, as portrayed in Figure 12. The solar system comprised a pair of solar panels, each with a capacity of 50 W, a 100 Ah - 12 V battery, a 30 A charging controller, and a solitary submerged DC water heater with a capacity of 50 W - 12 V. The active solar still had a heating element that allowed continuous water production for 24 hours. The findings indicated that the water productivity of the active solar still exhibited a 55% increase compared to that of the passive solar still. The trough temperature was highest in both models due to their steel construction. The study also found that water production was directly proportional to solar radiation intensity and ambient temperature.

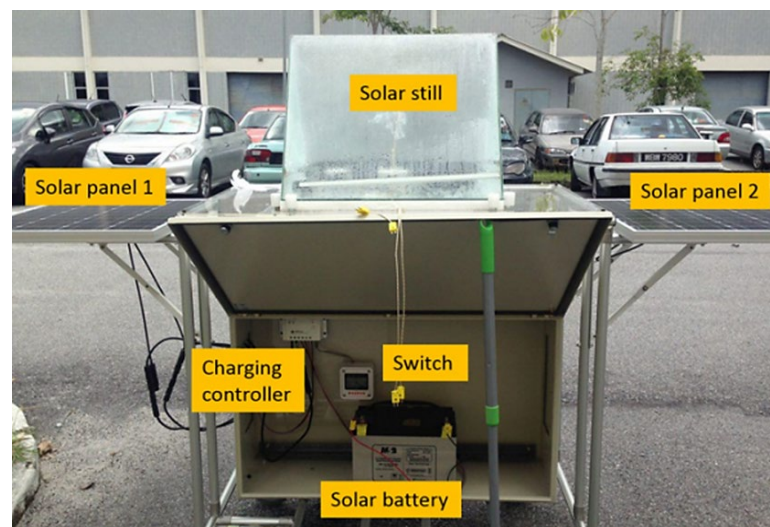

Figure 12: Active solar still setup [94]

3.9 Double-slope solar still integrated with a collector

Morad et al. [95] examined the performance of a double-slope solar still (DSSS) when used in combination with a flat plate collector (FPC). The thermal model was employed to calculate the interior and external heat transfer coefficients. The trial results demonstrate that active sun stills provide higher freshwater production ($10.06 \text{ l/m}^2 \text{ day}$) and internal thermal efficiency (80.6%) in comparison to passive solar stills ($7.8 \text{ l/m}^2 \text{ day}$ productivity and 57.1% internal efficiency). The results were obtained under precise circumstances, involving a brine depth of 1 cm in the basin, a glass cover thickness of 3 mm, and the flash approach for cover cooling with a cycle of 5 minutes of operation followed by 5 minutes of rest. Besides that, Hassan et al. [96] performed a test where they assessed the performance of a dual-slope solar still equipped with a tracked parabolic trough collector (TPTC) and operated it using salt water. The basin comprises sand fully saturated with saline water and an intricate system of steel wires. An analysis was conducted on the medium to assess its impact on freshwater generation using a modified solar still (TPTC) and a conventional solar still. The experiment was carried out during both the winter and summer seasons. According to the data, wire mesh and sand increase the upgraded system's daily freshwater production by 3.1% and 13.7% in the winter and 3.4% and 14.1% in the summer. The modified system's efficiency is enhanced by 3.3% and 15.3% in summer and 3.9% and 13.8% in winter by wire mesh and sand with salt water.

These studies are referenced to highlight the significance of incorporating advanced technologies, such as flat plate collectors and tracked parabolic trough collectors, as well as innovative basin materials like wire mesh and sand, to enhance the performance of solar still systems. By integrating these advancements, researchers and engineers can achieve higher freshwater production rates, improved system efficiency, and greater sustainability in solar-powered desalination processes.

3.10 Double slope solar still integrated with heat exchanger

In further development, the performance of active solar still greatly depends on the design of heat exchangers. However, there have been limited experimental studies investigating the impact of this parameter. Baspineiro et al. [97] performed a research study incorporating a newly developed multi-scale heat exchanger into an active solar connected to a parabolic trough

collector. The objective was to evaluate its efficiency compared to conventional designs like parallel channels and serpentine heat exchangers. The innovative heat exchanger, based on the construct theory, resulted in significant improvements. The solar still equipped with the new design produced 34.1% and 30.4% more distillate than parallel channels and serpentine heat exchangers, respectively. Furthermore, the new design achieved the highest total energy efficiency rating of 39.4%. These improvements were attributed to increased brine temperature, enhanced temperature difference between the evaporation and condensing surfaces, reduced pressure drop, and higher volumetric flow rate of the heat transfer fluid.

Sahota and Tiwari [98], conducted a research study to explore the potential use of nanofluids as thermal energy carriers in solar thermal applications. The study examines two separate systems: (A) an active double slope solar still connected to partially covered N-PVT-FPC without a helical heat exchanger, and (B) the same system but with a helical heat exchanger. The researchers developed an analytical formulation to describe these systems' characteristics accurately. They considered a 0.25% concentration of CuO, Al₂O₃, and TiO₂ metallic nanoparticles, four collectors, a 100 kg basin fluid (BF/NF) mass, and a mass flow rate of 0.03 kg/s. In system (A), the highest instantaneous gain thermal energy efficiencies for CuO, Al₂O₃, and TiO₂ are 80.18%, 71.67%, and 74.92% respectively. The highest instantaneous loss thermal energy efficiencies are 64.12%, 59.11%, and 64.77%, respectively. These values are significantly higher than the base fluid (water), with gain and loss efficiencies of 66.81% and 52.42%, respectively. Both system (A) and system (B) show higher productivity than using the base fluid. System (A) has CuO content of 32%, Al₂O₃ content of 19.23%, and TiO₂ content of 6.47%. System (B) has CuO content of 31.49%, Al₂O₃ content of 26.4%, and TiO₂ content of 7.26%. The study also evaluates both systems' thermal energy, exergy, and thermal exergy efficiency. Maurya et al. [99] dedicated their efforts to enhancing sun distillers' efficiency, mobility, and water purifying capabilities through the advancement of solar thermal desalination techniques. Environmental conditions significantly impact the performance of solar stills, making it essential to handle these variables. The researchers enhanced a double-slope single basin solar distiller (DSBD) by integrating a partly coated absorber panel with ZnO/PVC/Bioactive nanocomposite (ZPBN). The ZPBN material was produced by the solvent casting procedure and thoroughly analyzed. The implementation of ZPBN resulted in a substantial increase in drinking water production, with a maximum improvement of 126%, mostly attributed to enhanced absorption of solar energy. The DSBD demonstrated enhanced energy efficiency but a reduced exergy efficiency compared to a traditional solar distiller. The basin area covered with ZPBN exhibited energy payback durations ranging from 0.15 to 6.55 years. The DSBD achieved a lifetime reduction of 2.97 tons in carbon dioxide emissions and maintained a low cost per liter of \$0.0360. In general, the integration of ZPBN on the absorber plate showed outstanding environmental and energy efficiencies.

In summary, Table 1 presents the findings of a research study that examined the effectiveness of various heat addition methods in increasing the output of double-slope solar stills. The table provides a concise overview of the findings.

4. Economics of solar desalination processes

The expenses associated with constructing the unit and producing fresh water are paramount when designing a desalination system. Irrespective of the technology employed, desalination plants typically incur high costs related to energy consumption and carbon emissions [100,101]. Figure 13 illustrates the percentage cost breakdown of major desalination systems, including those driven by renewable energy sources (RES).

Several factors can considerably impact the cost per cubic meter of desalinated water. These factors include the capacity and kind of desalination plant, the source water (seawater or brackish water), the labor required, the geographical location, and the type of energy utilized, whether conventional or renewable. Conventional fuel and energy sources are commonly employed in phase change desalination technologies, which often demonstrate significant output capacities and substantial prices compared to membrane-based facilities [102,103]. The aforementioned disparity stems from the requirement of substantial quantities of fuel to enable the evaporation of seawater.

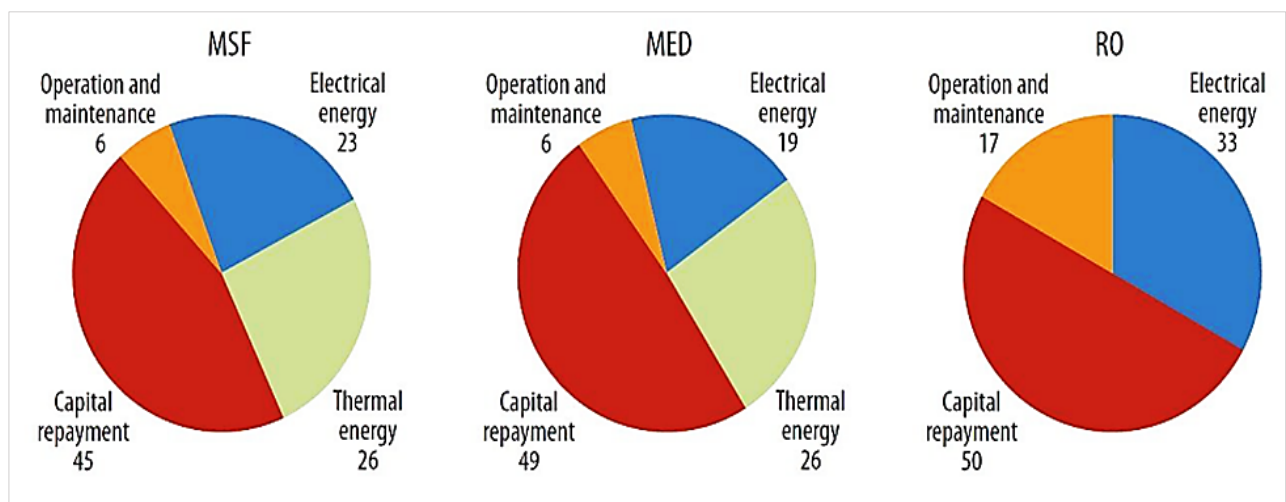

Figure 13: Major cost of desalination plants [104]

Table 1: Compares heat addition techniques for enhancing the productivity of a double-slope solar still

Solar Still Design	Heat Addition Method	Productivity	Outcomes	Ref.
Double-slope solar still	Evacuated tubular collectors	N/A	Employing N-evacuated tubular collectors in the system resulted in higher daily energy efficiency than similar configurations.	[68]
Double-slope solar still	Evacuated tube and parabolic concentrator	N/A	Theoretical study comparing NPCETCDS and NETCDS, showed improved performance with parabolic concentrator integration	[69]
Double-slope solar still	A tubular solar collector	549.77 kg/m ²	Modified solar still exhibited higher annual yield, exergy efficiency, and lower production cost than traditional solar.	[70]
Double-slope solar still	Utilization of thermoelectric heating and cooling	1032.5 L/m ² .year	Modified solar still produced water at a rate of 1032.5 L/m ² .year, cost of 0.1055 \$/L.	[72]
Double-slope solar still	Thermoelectric modules	3.2 times more than the glass part	The thermoelectric production rate was approximately 3.2 times greater than the glass component's.	[73]
Double-slope solar still	Thermoelectric heating modules	N/A	Exergy efficiency peaked at roughly 25% at 3 p.m., and the cost of distilled water ranged from 0.1422-0.237 \$/L.	[74]
Double-slope passive solar still (DSPSS)	Thermal modeling and experimental validation	Theoretical yield: 2.83, 3.64, 5.1, and 7.3 kg/m ²	Optimization of solar concentrating disc diameter: 0.5, 1, 1.5, and 2 m. Theoretical yield (kg/m ²): 2.83, 3.64, 5.1, and 7.3. Maximum water temperature (°C): 70.02, 75.8, 85.2, and 98.2.	[75]
Double slope solar still	PV-Heater	16 kg/m ² per day	CSSPVH design efficiently provides long-term potable water, is suitable for low solar radiation intensity areas, and complies with WHO drinking water standards. CSSPVH demonstrated approximately six times higher water output compared to conventional solar still.	[76]
Double slope solar still	External cooling fan and water heater	370%	370% increase in production with immersion-type water heaters. There was a slight decrease in productivity (4% and 8%) with an external cooling fan at different wind velocities. High concordance between experimental and numerical results.	[77]
Double slope solar still	Water heater + external fan	370%	370% increase in freshwater yield with DC water heaters. There is a slight decrease in productivity (7% and 15%) with an external cooling fan at different wind speeds. Favorable comparison with other experimental studies.	[78]
Double slope solar still	Cylindrical solar water heater	0.67 kg/m ² /day	Significant increase in temperature (8.94°C) and distillate mass production (0.67 kg/m ² /day) with the active solar still compared to the passive solar still.	[79]
Double-slope solar still	Internal reflective panels, collector/storage solar water heater	48%.	18.5% increase in distillate water production, 48.0% improvement in productivity.	[80]
Solar still	District heating network integration and granite stones	182%	Substantial enhancements in water generation and efficacy compared to conventional solar stills.	[81]
Double-slope solar still	Use of mirrors on the inside walls of single-slope basin solar stills	20%	Using mirrors on the inside walls of single-slope basin solar stills resulted in a 20% higher production of distilled water compared to double-basin solar stills.	[82]
---	PCMs (paraffin wax, stearic acid, lauric acid) in a copper cylinder	Paraffin wax: 1202 ml/m ² day increase	Maximum distillate yield was observed at 1 cm water depth for all PCMs; paraffin wax exhibited the highest improvement.	[83]
Double-slope solar still		3514 ml/m ²	Cylindrical sector solar stills (CSSS) achieved 16.01% higher accumulated productivity and 15.58% higher daily thermal efficiency than double-slope solar stills (DSSS).	[84]
Modified solar still	Internal reflector, heating coils, and nano-PCM	81% increase with internal reflector	Improved distillate production with internal reflector and nano-PCM; MSS-IR-PCM technology demonstrated economic viability.	[85]
Double-slope solar still	Integration of (PCM-TES) with double-slope solar stills	7.5 liters	Increased water production, extended operation time by 3 hours, 105% improvement in condensation and evaporation rates, and short payback period of 0.8 years.	[86]
Double-slope solar still	Silver nanoparticles with PCM	16%	Silver nanoparticles in PCM improved drinking water production and thermal efficiency, reduced the price per liter of drinkable water, and decreased the payback period.	[87]

Table 1: Continued

Solar Still Design	Heat Addition Method	Productivity	Outcomes	Ref.
Double-slope solar still	fins, water heater, and wick materials	245%	Active solar energy was still more cost-effective than bottled water, with bottled water being 117-283% more expensive.	[88]
Double-slope solar still	Cords-wick, reflectors, and condensation cycles	180%	25 and 35 cords provided the best performance with and without reflectors and condensation cycles; reflectors and condensation cycles with 35 cords yielded the highest efficiency and distillate production.	[89]
Solar still	PCMs, nanoparticles, and efficient solar reflectors	-	Examined improvements in solar stills to achieve optimal productivity, efficiency, and cost-effectiveness	[90]
Double-slope solar still	Addition of wicks	9012 ml/day with black cotton wick, 7040 ml/day with jute wick	Black cotton wick outperformed jute wick in terms of yield and thermal efficiency.	[91]
Single-slope solar still	Rectangular aluminum fins, bamboo cotton wick	19%	Bamboo cotton wick improved daily production in the solar still with rectangular aluminum fins.	[92]
Double-slope solar still	External spiral copper pipe as the water heater	20%	The production rates of water are affected by the intensity of solar radiation, the temperature of the water, and the surrounding ambient temperature. Active solar still had 20% higher water productivity than passive solar still.	[93]
Double-slope solar still	Active and passive models, solar panels	55%	Active solar still exhibited a 55% increase in water productivity compared to passive solar still. Water production is directly proportional to solar radiation intensity and ambient temperature.	[94]
Double-slope solar still	Flat plate collector	10.06 l/m ² day	Modified solar still had higher freshwater production (10.06 l/m ² day) and internal thermal efficiency (80.6%) compared to passive solar still (7.8 l/m ² day productivity and 57.1% internal efficiency).	[95]
Double-slope solar still	Tracked parabolic trough collector (TPTC)	-	Wire mesh and sand increased the upgraded system's daily freshwater production by 3.1% to 14.1% and enhanced efficiency by 3.3% to 15.3%, depending on the season.	[96]
Double-slope solar still	Multi-scale heat exchanger	34.1% and 30.4% higher compared to parallel channels and serpentine heat exchangers	Active solar still with the new heat exchanger produced 34.1% to 39.4% more total distillate than conventional designs. Achieved the highest overall energy efficiency of 39.4%.	[97]
Double-slope solar still	N-PVT-FPC with and without helically coiled heat exchanger	32% (CuO), 19.23% (Al ₂ O ₃), 6.47% (TiO ₂)	systems with nanofluids exhibited higher thermal energy efficiency, productivity, and exergy efficiency compared to the base fluid (water).	[98]
Double-slope solar still	Partly coated absorber panel with ZnO/PVC/Bioactive nanocomposite (ZPBN)	126%	ZPBN integration substantially increased drinking water production and demonstrated environmental and energy efficiencies.	[99]

5. Discussion of recent advances in double slope solar stills

Recent advancements in double-slope solar stills have focused on improving heat addition techniques to enhance efficiency and freshwater production. Various methods have been explored, including the integration of evacuated tubular collectors (ETC), thermoelectric modules, photovoltaic thermal (PVT) systems, immersion water heaters, and phase change materials (PCMs).

1. Evacuated Tubular Collectors (ETC) have shown promise in increasing daily energy and life cycle conversion efficiency. These collectors maximize thermal influx into the solar stills by minimizing convective heat transmission.
2. Thermoelectric Modules create significant temperature differentials between water and glass surfaces, improving evaporation rates and overall efficiency.
3. Photovoltaic thermal (PVT) systems and immersion water heaters utilize solar energy to heat water, increasing output rates, particularly in remote areas with limited freshwater sources.

4. Phase Change Materials (PCMs) and External Cooling Fans: Incorporating PCMs and external cooling fans optimizes thermal energy storage and reduces heat loss, enhancing efficiency and freshwater production.
5. Innovative Designs: Active solar stills with combined fins, water heaters, and wick materials have shown promise in increasing productivity, especially in isolated regions.

These advancements underscore the importance of active heat addition techniques and innovative design modifications in advancing sustainable water desalination technologies. Further research is needed to optimize these techniques and address challenges such as scalability and cost-effectiveness for widespread adoption and effective mitigation of water scarcity issues.

6. Conclusions and future directions in the field

This paper reviews the latest techniques to enhance the productivity of double-slope solar stills. It begins with an overview of the global water scarcity crisis and the current state of desalination technology. The paper then discusses different heat addition techniques for implementing solar water desalination, focusing on published research on solar-based desalination techniques.

- The productivity of double-slope solar stills may be considerably enhanced by several modifications. The most successful improvements include evaporation enhancement, heat transfer enhancement, and condensation enhancement.
- No matter the weather, solar stills can be used in both hot and humid locations. For this reason, they are a viable option for water purification in several countries worldwide.
- Utilizing thermoelectric modules in a double-sloped solar system has still resulted in a significant 250% enhancement in water output. Applying a thermoelectric module to the water in the distillation vessel augmented the rate of evaporation and the quantity of water condensing on the glass cover.
- The water output of a double-slope solar still equipped with a photovoltaic heater is around six times more than that of a traditional solar still. This is a notable enhancement, resulting in the CSSPVH being a more effective design for delivering safe drinking water over an extended time.
- Adding a water heater to the base tank of a solar still rapidly increases the water temperature, increasing production by around 370%. As wind speed increases, solar still production drops. When an external cooling fan is employed to cool the solar still's glass surface, productivity is still reduced by 4% and 8% for wind speeds of 7 m/s and 9 m/s, respectively.
- Integrating active components into double-slope solar stills can make them more expensive to build and operate. However, the increased water production can offset these costs in many cases.
- Integrating a double-slope solar still with a multi-scale heat exchanger can increase its productivity by up to 34%. This is because the multi-scale heat exchanger can provide a more efficient heat transfer between the water in the basin and the heat transfer fluid.

This review summarizes key findings from studies on double-slope solar stills to provide researchers with insights for developing new designs with optimal parameters for increased daily production. Further research is recommended in the following areas:

- Although the studies indicate encouraging outcomes, conducting real-world assessments of these systems is crucial to evaluate their effectiveness in realistic circumstances.
- Examine the incorporation of various heat addition strategies to optimize heat transmission efficiency in solar stills. This may include synergistically integrating reflective coatings, heat exchangers, and phase change materials to yield substantial enhancements in performance.
- Investigate concentrating solar power technologies into double-slope solar stills, such as parabolic troughs or solar power towers. This hybrid system could provide additional heat input to the stills, increasing evaporation rates and overall productivity.

Author contributions

Conceptualization, M. Murad, W. ALawee, H. Dhahad and Z. Omara.; formal analysis, W. ALawee.; investigation, M. Murad.; methodology, W. ALawee.; project administration, M. Murad, W. ALawee and H. Dhahad.; supervision, H. Dhahad and Z. Omara.; visualization, W. ALawee.; writing—original draft preparation, M. Murad.; writing—review and editing, M. Murad. All authors have read and agreed to the published version of the manuscript.

Funding

This research received no specific grant from any funding agency in the public, commercial, or not-for-profit sectors.

Data availability statement

The data that support the findings of this study are available on request from the corresponding author.

Conflicts of interest

The authors declare that there is no conflict of interest.

References

- [1] K. A. Hammood, et al., Effects of Magnetic Field on the Performance of Solar Distillers: A Review Study, *Eng. Technol. J.*, 41 (2022) 121-131. <http://doi.org/10.30684/etj.2022.134576.1240>
- [2] A. M. Manokar, et al., Review of different methods employed in pyramidal solar still desalination to augment the yield of freshwater, *Desalin. Water Treat.*, 136 (2018) 20-30. <http://doi.org/10.5004/dwt.2018.23188>
- [3] Kabeel, A., et al., A comprehensive review of tubular solar still designs, performance, and economic analysis, *J. Cleaner Prod.*, 246 (2020) 119030. <https://doi.org/10.1016/j.jclepro.2019.119030>
- [4] A. A. El-Sebaili, et al., Effect of fin configuration parameters on single basin solar still performance. *Desalination*, 365 (2015) 15-24. <https://doi.org/10.1016/j.desal.2015.02.002>
- [5] K. A. Hammoodi, et al., Pyramid solar distillers: A comprehensive review of recent techniques, *Results Eng.*, 18 (2023) 101157. <https://doi.org/10.1016/j.rineng.2023.101157>
- [6] S.J. Gnanaraj and V. V. Velmurugan, Experimental investigation on the performance of modified single basin double slope solar stills, *Int. J. Ambient Energy*, 43 (2022) 206-215. <https://doi.org/10.1080/01430750.2019.1636861>
- [7] D.D.W. Rufuss, et al., Solar stills: A comprehensive review of designs, performance and material advances, *Renewable Sustainable Energy Rev.*, 63 (2016) 464-496. <https://doi.org/10.1016/j.rser.2016.05.068>
- [8] K.A. Hammoodi, et al., A detailed review of the factors impacting pyramid type solar still performance, *Alexandria Eng. J.*, 66 (2023) 123-154. <https://doi.org/10.1016/j.aej.2022.12.006>
- [9] O. Badran, Theoretical analysis of solar distillation using active solar still, *Int. J. Therm. Environ. Eng.*, 3 (2011) 113-120. <http://dx.doi.org/10.5383/ijtee.03.02.009>
- [10] A. Shokri and MS Fard, Techno-economic assessment of water desalination: Future outlooks and challenges, *Process Saf. Environ. Prot.*, 169 (2023) 564-578. <https://doi.org/10.1016/j.psep.2022.11.007>
- [11] A. Sangeetha, et al., A review on PCM and nanofluid for various productivity enhancement methods for double slope solar still: Future challenge and current water issues, *Desalination*, 551 (2023) 116367. <https://doi.org/10.1016/j.desal.2022.116367>
- [12] R. Agrawal, et al., Augmenting the productivity of double slope solar still by incorporating sensible and latent heat storage materials, *Int. J. Ambient Energy*, 44 (2023) 616-625. <https://doi.org/10.1080/01430750.2022.2140192>
- [13] S.W. Sharshir, et al., Performance enhancement of stepped double slope solar still by using nanoparticles and linen wicks: energy, exergy and economic analysis, *Appl. Therm. Eng.*, 174 (2020) 115278. <https://doi.org/10.1016/j.applthermaleng.2020.115278>
- [14] I. Mohan, et al., A review on solar still: a simple desalination technology to obtain potable water, *Int. J. Ambient Energy*, 40 (2019) 335-342. <http://dx.doi.org/10.1080/01430750.2017.1393776>
- [15] H. Panchal, et al., Various techniques to enhance distillate output of tubular solar still: a review, *Groundwater Sustainable Dev.*, 9 (2019) 100268. <https://doi.org/10.1016/j.gsd.2019.100268>
- [16] A.K. Singh, et al., Water purification using solar still with/without nano-fluid: a review, *Mater. Today: Proc.*, 21 (2020). 1700-1706. <https://doi.org/10.1016/j.matpr.2019.12.025>
- [17] P. Prakash and V. Velmurugan, Parameters influencing the productivity of solar stills—A review, *Renewable Sustainable Energy Rev.*, 49 (2015) 585-609. <https://doi.org/10.1016/j.rser.2015.04.136>
- [18] W. H. Alawee, Improving the productivity of single effect double slope solar still by modification simple, *J. Eng.*, 21 (2015) 50-60. <https://doi.org/10.31026/j.eng.2015.08.13>
- [19] A.Z. Al-Garni, Enhancing the solar still using immersion type water heater productivity and the effect of external cooling fan in winter, *Appl. Sol. Energy*, 48 (2012) 193-200. <https://doi.org/10.3103/S0003701X12030048>
- [20] M. Dubey and D.R. Mishra, Experimental evaluation of double slope solar still augmented with ferrite ring magnets and a black cotton cloth, *Int. J. Ambient Energy*, 43 (2022) 1751-1762. <https://doi.org/10.1080/01430750.2020.1722746>
- [21] T. Rajaseenivasan, K. Kalidasa Murugavel and T. Elango, Performance and exergy analysis of a double-basin solar still with different materials in basin, *Desalin. Water Treat.*, 55 (2015) 1786-1794. <https://doi.org/10.1080/19443994.2014.928800>
- [22] Y. Zhang, et al., Application of solar energy in water treatment processes: A review, *Desalination*, 428 (2018) 116-145. <https://doi.org/10.1016/j.desal.2017.11.020>

- [23] A. M. Manokar, K.K. Murugavel and G. Esakkimuthu, Different parameters affecting the rate of evaporation and condensation on passive solar still—A review, *Renewable Sustainable Energy Rev.*, 38 (2014) 309-322. <https://doi.org/10.1016/j.rser.2014.05.092>
- [24] A. Dubey, S. Singh, and S. Tyagi, Advances in design and performance of dual slope solar still: A review, *Solar Energy*, 244 (2022) 189-217. <https://doi.org/10.1016/j.solener.2022.08.050>
- [25] P. Durkaieswaran and K.K. Murugavel, Various special designs of single basin passive solar still—A review, *Renewable Sustainable Energy Rev.*, 49 (2015) 1048-1060. <https://doi.org/10.1016/j.rser.2015.04.111>
- [26] K. Sampathkumar et al., Active solar distillation—A detailed review, *Renewable Sustainable Energy Rev.*, 14 (2010) 1503-1526. <https://doi.org/10.1016/j.rser.2010.01.023>
- [27] T. Babalola, A. Boyo, and R. Kesinro, Effect of Water Depth and Temperature on the Productivity of a Double Slope Solar Still', *J. Energy Nat. Resour.*, 4 (2015) 1-4. <http://dx.doi.org/10.11648/j.jenr.20150401.11>
- [28] T. Arunkumar, H.W. Lim, and S.J. Lee, A review on efficiently integrated passive distillation systems for active solar steam evaporation, *Renewable Sustainable Energy Rev.*, 155 (2022) 111894. <https://doi.org/10.1016/j.rser.2021.111894>
- [29] M. Qadir, et al., Non-conventional water resources and opportunities for water augmentation to achieve food security in water scarce countries, *Agric. Water Manage.*, 87 (2007) 2-22. <https://doi.org/10.1016/j.agwat.2006.03.018>
- [30] K. H. AL-Zaedy, Experimental study on enhancement of single-basin solar still using dye solutions, *Eng. Technol. J.*, 30 (2012) 3112-3125. <https://doi.org/10.30684/etj.30.18.1>
- [31] A. M. Manokar, et al., Integrated PV/T solar still-A mini-review, *Desalination*, 435 (2018) 259-267. <https://doi.org/10.1016/j.desal.2017.04.022>
- [32] S. Kalaivani and S. Radhakrishnan, Heat mass transfer and thermophysical analysis for pyramid type solar still, *Int. J. Sci. Res.*, 2 (2013) 181-184.
- [33] A. M. El-Nashar, Seasonal effect of dust deposition on a field of evacuated tube collectors on the performance of a solar desalination plant, *Desalination*, 239 (2009) 66-81. <https://doi.org/10.1016/j.desal.2008.03.007>
- [34] Organization, WH, The World health report: 2004: changing history, 2004: World Health Organization.
- [35] A. F. Mashaly, et al., Predictive model for assessing and optimizing solar still performance using artificial neural network under hyper arid environment, *Solar Energy*, 118 (2015) 41-58. <https://doi.org/10.1016/j.solener.2015.05.013>
- [36] G. N. Tiwari, and L. Sahota, *Advanced solar-distillation systems: basic principles, thermal modeling, and its application*, Springer, 2017. <http://dx.doi.org/10.1007/978-981-10-4672-8>
- [37] M. Karrabi, Removal of nitrate from contaminated groundwater using solar membrane distillation, *Eng. Technol. J., Part C*, 37 (2019) 327-332 . <https://doi.org/10.30684/etj.37.3C.4>
- [38] S.T. Ahmed, Physical and Chemical Characteristics Comparison of the Drinking Water and Water Produced from the Conventional and Modification Solar Water Distillery, *Eng. Technol. J., Part A*, 37 (2019) 214-221. . <https://doi.org/10.30684/etj.37.6A.5>
- [39] S. Gnanaraj, J. Patrick and M. Annaamalai, Enhancing solar still productivity by optimizing operational parameters, *Desalin. Water Treat.*, 254 (2022) 1-14. <https://doi.org/10.5004/dwt.2022.28287>
- [40] A. Abdullah, et al., Performance evaluation of a humidification–dehumidification unit integrated with wick solar stills under different operating conditions, *Desalination*, 441 (2018) 52-61. <https://doi.org/10.1016/j.desal.2018.04.024>
- [41] T. Farge, K. Sultan, and A. Ahmed, Experimental study of the performance water distillation device by using solar energy, *Eng. Technol. J., Part A*, 35 (2017) 653-659. <http://dx.doi.org/10.30684/etj.35.6A.14>
- [42] K. A. Hammoodi, et al., Enhancement of Pyramid Solar Still Productivity Through Wick Material and Reflective Applications in Iraqi Conditions, *Math. Modell. Eng. Probl.*, 10 (2023) 1548-1556 . <https://doi.org/10.18280/mmep.100506>
- [43] K.A. Hammoodi, et al., Experimental study on pyramid solar distiller performance with applying magnet field under various operating conditions, *Energy Sources Part A*, 45 (2023) 11410-11423. <https://doi.org/10.1080/15567036.2023.2258081>
- [44] S. Radwan A. Hassanain, and M. Abu-Zeid, Single slope solar still for sea water distillation, *World Appl. Sci. J.*, 7 (2009) 485-497. <http://dx.doi.org/10.13140/RG.2.2.35804.59525>
- [45] M. S. Islam, et al., Desalination technologies for developing countries: a review, *J. Sci. Res.*, 10 (2018) 77-97. <http://dx.doi.org/10.3329/jsr.v10i1.33179>
- [46] S. Manju, and N. Sagar, Renewable energy integrated desalination: A sustainable solution to overcome future fresh-water scarcity in India, *Renewable Sustainable Energy Rev.*, 73 (2017) 594-609. <https://doi.org/10.1016/j.rser.2017.01.164>

- [47] I. Ullah and M.G. Rasul, Recent developments in solar thermal desalination technologies: a review, *Energies*, 12 (2018) 119. <https://doi.org/10.3390/en12010119>
- [48] D. Zarzo and D. Prats, Desalination and energy consumption, What can we expect in the near future?, *Desalination*, 427 (2018) 1-9. <https://doi.org/10.1016/j.desal.2017.10.046>
- [49] H. Hoff, Global water resources and their management, *Curr. Res. Environ. Sustainability*, 1 (2009) 141-147. <https://doi.org/10.1016/j.cosust.2009.10.001>
- [50] A. Giwa, et al., Brine management methods: Recent innovations and current status, *Desalination*, 407 (2017) 1-23. <https://doi.org/10.1016/j.desal.2016.12.008>
- [51] H. Al-Madhhachi, G. F. Smaism, Experimental and numerical investigations with environmental impacts of affordable square pyramid solar still, *Solar Energy*, 216 (2021) 314. <http://dx.doi.org/10.1016/j.solener.2020.12.051>
- [52] M. A. Al-Obaidi, et al., Evaluation of Solar Energy Powered Seawater Desalination Processes: A Review ,*Energies*, 15 (2022) 6562. <https://doi.org/10.3390/en15186562>
- [53] M. A. Abdelkareem, et al., Recent progress in the use of renewable energy sources to power water desalination plants , *Desalination*, 435(2018)97-113. <https://doi.org/10.1016/j.desal.2017.11.018>
- [54] A. Aende, J. Gardy, A. Hassanpour, Seawater desalination: A review of forward osmosis technique, its challenges, and future prospects ,*Processes*, 8(2020) 901. <https://doi.org/10.3390/pr8080901>
- [55] K. A. Hammoodi, et al., A detailed review of the factors impacting pyramid type solar still performance ,*Alex. Eng. J.*, 66 (٢٠٢٣)123-154. <http://dx.doi.org/10.1016/j.aej.2022.12.006>
- [56] H.M. Hussen, et al., An experimental comparison study between four different designs of solar stills, *Case Stud. Therm. Eng.*, 44 (2023)102841. <https://doi.org/10.1016/j.csite.2023.102841>
- [57] A. Abdullah, Z. Omara, An Experimental Comparison Study between Four Different Designs of Solar Still, Avail SSRN, (2022) 4071717. <https://dx.doi.org/10.2139/ssrn.4071717>
- [58] M.Youshanlouei, S. Motlagh, H. Soltanipour, The effect of magnetic field on the performance improvement of a conventional solar still: a numerical study, *Environ. Sci. Pollut. Res.*, 28 (2021) 31778-31791. <https://doi.org/10.1007/s11356-021-12947-1>
- [59] R. Sathyamurthy, et al., Factors affecting the performance of triangular pyramid solar still, *Desalination.*, 344 (2014) 383-390. <https://doi.org/10.1016/j.desal.2014.04.005>
- [60] A. Singh, et al., Active solar distillation technology: a wide overview, *Desalination*, 493 (2020) 114652. <https://doi.org/10.1016/j.desal.2020.114652>
- [61] A. Muftah, et al., Factors affecting basin type solar still productivity: A detailed review, *Renew. Sustain. Energy Rev.*, 32 (2014) 430-447. <https://doi.org/10.1016/j.rser.2013.12.052>
- [62] A. El-Sebaii, Effect of wind speed on active and passive solar stills, *Energy Convers. Manag.*, 45 (2004) 1187-1204. <https://doi.org/10.1016/j.enconman.2003.09.036>
- [63] A. Kabeel, Z. Omara, M. Younes, Techniques used to improve the performance of the stepped solar still—A review, *Renew. Sustain. Energy Rev.*, 46 (2015)178-188. <https://doi.org/10.1016/j.rser.2015.02.053>
- [64] M. Keshtkar, M. Eslami, K. Jafarpur, Effect of design parameters on performance of passive basin solar stills considering instantaneous ambient conditions: a transient CFD modeling, *Solar Energy*, 201 (2020) 884-907. <https://doi.org/10.1016/j.solener.2020.03.068>
- [65] K. V. Modi, et al., Impact of orientation and water depth on productivity of single-basin dual-slope solar still with Al₂O₃ and CuO nanoparticles, *J. Therm. Anal. Calorim.*, 143 (2021) 899-913. <https://doi.org/10.1007/s10973-020-09351-1>
- [66] D. Jin, et al., Numerical investigation of heat transfer enhancement in a solar air heater roughened by multiple V-shaped ribs, *Renew. Energy.*, 134 (2019) 78-88. <https://doi.org/10.1016/j.renene.2018.11.016>
- [67] R. Tripathi, G. Tiwari, Effect of size and material of a semi-cylindrical condensing cover on heat and mass transfer for distillation, *Desalination*, 166 (2004) 231-241. <https://doi.org/10.1016/j.desal.2004.06.078>
- [68] D. Singh. G. Tiwari, Analytical characteristic equation of N identical evacuated tubular collectors integrated double slope solar still, *J. Sol. Energy. Eng.*, 139 (2017) 69. <https://doi.org/10.1115/1.4036855>
- [69] Sharma, S.K., et al., Energy metrics and efficiency analyses of double slope solar distiller unit augmented with N identical parabolic concentrator integrated evacuated tubular collectors: a comparative study. *Desalination and Water Treatment*, 195(2020) 40-56. <https://doi: 10.5004/dwt.2020.25919>

- [70] O. Bait, Exergy, environ–economic and economic analyses of a tubular solar water heater assisted solar still, *J. Clean. Prod.*, 212 (2019) 630-646. <https://doi.org/10.1016/j.jclepro.2018.12.015>
- [71] M. Elgendi, A. Kabeel, F. Essa, Improving the solar still productivity using thermoelectric materials: A review, *Alex. Eng. J.*, 65 (2023) 963-982. <https://doi.org/10.1016/j.aej.2022.10.011>
- [72] S. Shoeibi, et al., Application of simultaneous thermoelectric cooling and heating to improve the performance of a solar still: an experimental study and exergy analysis, *Appl. Energy*, 263 (2020) 114581. <https://doi.org/10.1016/j.apenergy.2020.114581>
- [73] A. Dehghan, A. Afshari, N. Rahbar, Thermal modeling and exergetic analysis of a thermoelectric assisted solar still, *Solar Energy*, 115 (2015) 277-288. <https://doi.org/10.1016/j.solener.2015.02.038>
- [74] N. Rahbar, A. Gharaiian, S. Rashidi, Exergy and economic analysis for a double slope solar still equipped by thermoelectric heating modules-an experimental investigation, *Desalination*, 420 (2017)106-113. <https://doi.org/10.1016/j.desal.2017.07.005>
- [75] A .Krishna, K. Ritwin, S. Tiwari, Performance analysis based on energy and exergy output of double slope passive and active solar still, *Environ. Prog. Sustain. Energy.*, 42 (2023) e13949. <https://doi.org/10.1002/ep.13949>
- [76] A. Riahi, et al., Sustainable potable water production using a solar still with photovoltaic modules-AC heater, *Desalin. Water Treat.*, 57(2016)14929-14944. <http://dx.doi.org/10.1080/19443994.2015.1070285>
- [77] A. Al-Garni, Productivity enhancement of solar still using water heater and cooling fan, *J. Sol. Energy Eng. Aug.*, 134 (2012) 031006 . <http://dx.doi.org/10.1115/1.4005760>
- [78] A. Al-Hamadani, A. Yaseen, Experimental Study of Multi Effect stages PV Panels Solar Still to Enhance the Productivity by Utilizing Water Heater and Cooling Fan, *J. Univ. Babylon Eng. Sci.*, 27 (2019) 275-286.
- [79] O. Bait, M. SI-Ameur, A. Benmoussa, Numerical Approach of a Double Slope Solar Still Combined with a Cylindrical Solar Water Heater: Mass and Heat Energy Balance Mathematical Model, *J. Polytechnic .*, 18 (2015) 227-234.
- [80] W. Alawee, H. Dhahad, T. Mohamed, An Experimental study on improving the performance of a double slope solar still, *Int. Conf. Sustain. Agric. Energy Ind. Reg. Global Context*, 2015.
- [81] R. Dhivagar, et al., Performance analysis of solar desalination using crushed granite stone as an energy storage material and the integration of solar district heating, *Energy Sources A: Recov. Util. Environ. Eff.*, 46 (2024) 1370-1388. <https://doi.org/10.1080/15567036.2023.2299693>
- [82] I. Al-Hayeka, O. Badran, The effect of using different designs of solar stills on water distillation, *Desalination*, 169 (2004)121-127. <https://doi.org/10.1016/j.desal.2004.08.013>
- [83] V. Sonker, et al., Solar distillation using three different phase change materials stored in a copper cylinder, *Energy Rep.*, 5 (2019)1532-1542. <https://doi.org/10.1016/j.egy.2019.10.023>
- [84] M. El-Sebaey, et al., Experimental study with thermal and economical analysis for some modifications on cylindrical sector and double slope, single basin solar still, *Case Stud. Therm. Eng.*, 49 (2023) 103310. <https://doi.org/10.1016/j.csite.2023.103310>
- [85] A. Abdullah, et al., Enhancing a solar still's performance by preheating the feed water and employing phase-change material, *Alex. Eng. J.*, 77 (2023) 395-405. <https://doi.org/10.1016/j.aej.2023.07.002>
- [86] L. Afolabi, et al., Experimental investigation of double slope solar still integrated with PCM nanoadditives microencapsulated thermal energy storage, *Desalination*, 553 (2023)116477. <https://doi.org/10.1016/j.desal.2023.116477>
- [87] M. Shajahan, et al., Evaluation of efficiency of double slope solar still and drinking water yield using silver nanoparticle mixed with phase change material, *Energy Sources A: Recovery, Util. Environ. Eff.*, 44 (2022)8679-8693. <https://doi.org/10.1080/15567036.2022.2120572>
- [88] A. Samuel, et al., Design and Investigation of an Effective Solar Still Applicable to Remote Islands, *Water*, 14 (2022) 703. <https://doi.org/10.3390/w14050703>
- [89] W. Alawee, et al., Utilizing the dangled jute cords, reflectors, and condensation cycle to improve the double sloped distiller performance, *Solar Energy*, 267 (2024)112237. <https://doi.org/10.1016/j.solener.2023.112237>
- [90] M. Chaichan, et al., Advanced techniques for enhancing solar distiller productivity: a review, *Energy Sources A: Recovery Util. Environ. Eff.*, 46 (2024)736-772. <http://dx.doi.org/10.1080/15567036.2023.2289559>
- [91] P. Pal, et al., Performance analysis of modified basin type double slope multi–wick solar still, *Desalination*, 422 (2017) 68-82. <https://doi.org/10.1016/j.desal.2017.08.009>

- [92] M. Bhargva, et al., Productivity Augmentation of a Solar Still with Rectangular Fins and Bamboo Cotton Wick, *J. Sol. Energy Res.*, 8 (2023)1410-1416.
- [93] E. Al-Qadami, et al., Yield efficiency evaluation of double slope solar stills connected with external spiral copper for potable water production, *J. Ecol. Eng.*, 20 (2019) 176-186. <https://doi.org/10.12911/22998993/108654>
- [94] E. Al-Qadami, et al., Productivity enhancement of a double slope solar still coupled with a solar system, *J. Ecol. Eng.*, 21 (2020) 255-263. <https://doi.org/10.12911/22998993/118293>
- [95] M. Morad, H. El-Maghawry, K. Wasfy, Improving the double slope solar still performance by using flat-plate solar collector and cooling glass cover, *Desalination*, 373 (2015) 1- 9. <https://doi.org/10.1016/j.desal.2015.06.017>
- [96] H. Hassan, M. Ahmed, M. Fathy, Experimental work on the effect of saline water medium on the performance of solar still with tracked parabolic trough collector (TPTC), *Renew. Energy*, 135 (2019)136-147. <https://doi.org/10.1016/j.renene.2018.11.112>
- [97] C. Baspineiro, J. Franco, V. Flexer, Performance of a double-slope solar still for the concentration of lithium rich brines with concomitant fresh water recovery, *Sci. Total Environ.*, 791 (2021)148192. <https://doi.org/10.1016/j.scitotenv.2021.148192>
- [98] L. Sahota, G. Tiwari, Analytical characteristic equation of nanofluid loaded active double slope solar still coupled with helically coiled heat exchanger, *Energy Conv. Manag.*, 135 (2017) 308-326. <https://doi.org/10.1016/j.enconman.2016.12.078>
- [99] A. Maurya, et al., Use of absorber plate built of ZnO/PVC/Bioactivation modified epoxy nanocomposites to improvement of double-effect Solar Distiller productivity analyzing the Energy, Exergo-environment and Enviro-economical, *J. Clean. Prod.*, 434 (2024)139601. <https://doi.org/10.1016/j.jclepro.2023.139601>
- [100] E. Delyannis, A. Delyannis, Economics of solar stills, *Desalination*, 52 (1985)167-176. [https://doi.org/10.1016/0011-9164\(85\)85006-2](https://doi.org/10.1016/0011-9164(85)85006-2)
- [101] A. Abdullah, et al., Utilizing a single slope solar still with copper heating coil, external condenser, phase change material, along with internal and external reflectors—experimental study, *J. Energy Storage*,63(2023)106899. <http://dx.doi.org/10.1016/j.est.2023.106899>
- [102] N. Habib, et al., Carbon nanotubes/paraffin wax nanocomposite for improving the performance of a solar air heating system, *Therm. Sci. Eng. Prog.*, 23 (2021)100877. <https://doi.org/10.1016/j.tsep.2021.100877>
- [103] M. Attia, et al., Phosphate bed as energy storage materials for augmentation of conventional solar still productivity, *Environ. Prog. Sustain. Energy.*, 40 (2021) e13581. <https://doi.org/10.1002/ep.13581>
- [104] A. Alkaisi, R. Mossad, A. Barforoush, A review of the water desalination systems integrated with renewable energy, *Energy Proc.*, 110 (2017) 268-274. <https://doi.org/10.1016/j.egypro.2017.03.138>