

STABILITY ANALYSIS AND DESIGN OF PRESSURE CONTROL SYSTEM

Dr. Duraid Fadhel Ahmed **Dr. Salam K. Hassan** **Mr. Lokman Aziz Abdul-Karim**
 Chem. Eng. Dept. Chem. Eng. Dept. University of Arbil
 University of Tikrit University of Baghdad.

ABSTRACT

The performance of pressure control system and stability analysis was studied for different types of controllers. A theoretical model for closed-loop system is developed and dynamic behavior of the control system was studied by introducing a step change in the pressure of the inlet stream. The results show that the theoretical response is faster than the experimental response due to the lags of the control valve and measuring elements. The pressure control system is stable for all conditions and for different control action because the real parts of roots of characteristics equation are negative but the response at PID controller is oscillatory stable. when PID controller used the response is improve due to eliminate the offset and stabilizing effect of derivative allow the proportional gain to be increased and increasing the speed of response compared to proportional and proportional-integral controllers.

KEYWORDS: Pressure Control, Stability, PID Control.

NOTATIONS

C: Capacitance, (kg/bar).

G(s): Transfer function.

K_{p1} , K_{p1} : The steady state gains of the load and process respectively, (-).

K_c , K_m , K_v : The gains of controller, measurement element and control valve respectively, (-).

Q: Volumetric flow rate, (m^3/hr).

R: Flow resistance in the valve, (bar.sec/Kg).

K_{R1} , K_{S1} , K_{R2} , K_{R3} : The gains of closed-loop system, (-).

P: pressure, (bar).

τ : Time constant of pressure system. (sec)

τ_{R1} , τ_{S1} , τ_{R2} , τ_{R3} : Effective time constant of closed-loop system. (sec)

INTRODUCTION

Pressure control is important to many processes including gas distribution system, furnaces, dryers, hydraulic system, ventilation, throttle units, gas/liquid separation, and boiler water treatment ^[1]. The pressure control is difficult to control for number of reasons, first, the process is very sensitive to disturbances at high pressure of gases; second, the difficulty of pressure control can be related to the wide range of pressure. Pressure control is important to appreciate the diverse nature of these applications because they vary greatly in their degree of difficulty, and to this extent, it is quite meaningless to generalize about pressure control.

The conventional control is used for the vast majority of continuous control problems in the process industry. Experience gained during the long period of its use has led to a detailed understanding of the properties of PI control in the systems. Satisfactory performance of the algorithm in a large number of industrial applications has

resulted in a high degree of confidence in PI control. In this section, a survey of literature is presented, concerning pressure control, based on the techniques used.

Fletcher et al. ^[2] applied multivariable control strategies to a gas pressure reduction station. They concluded that the multivariable control has both satisfactory static and a dynamic property even through the reduction system is very sensitive at high pressure. French et al. ^[3] proposed a fast adaptive control of pressure measurement in gas scrubber process. It is based upon the use of numerical methods to accelerate the convergence in parameter adaptive control algorithms.

Fletcher et al. ^[4] applied the fuzzy logic controller to a two-stage high-pressure gas reduction station. Harris ^[5] applied the fuzzy logic controller to the gas filter. They concluded that fuzzy controller can give as good, if not better results than PID controller in spite of the limit cycle which could be reduced or eliminated by proper controller tuning. Zlokovitz ^[6,7] has developed adaptive predictive control of pressure control of gas station. This method utilizes one

controller at the district regulator station and one controller at the system low pressure point.

Alessandro ^[8] has developed adaptive control based on general dynamic model. Since the model had built up was time to think about performance improvements. Luyben ^[9] used simple regulatory control of the Eastman process. Johan ^[10] treats methods to handle nonlinearities in a throttle unit. The approach has been to first design a linear controller based on the results from system identification, and then to develop an adaptive updating law estimating uncertain parameters of the throttle. John ^[11] described the application of pressure control in gas/liquid phase separator includes a fluid inlet, a vapor outlet, a liquid outlet, and first and second valves disposed in fluid communication with liquid outlet. Bernd et al. ^[12] developed pressure control method by using computer control. This method relates to the pressure control for program-controlled drive of at least one pressure actuating member in order influence the hydraulic constellation in a transmission via the pressure. Frank ^[13] used cascade pressure/flow control in gas analyzer measuring cell. A closed, gaseous fluid

analyzing system includes a gas analyzer measuring cell that operates under substantially stable conditions by controlling both pressure and flow rate of a plurality of differing gas streams while passing through the analyzer measuring cell.

In this paper, study the dynamic behavior of a pressure process control by introducing a step change in pressure of the inlet stream and measuring pressure of the vessel. A theoretical model for the pressure process control at different control methods was developed. The study of the dynamic behavior of the pressure process was carried under the implementation of many different control strategies. The implemented control strategies were proportional (P), proportional-integral (PI), and proportional-integral-derivative (PID) methods for pressure control. Comparisons between the different control systems and stability analysis have been made to observe the best control that can be recommended for the pressure control system.

THEORY

1-Mathematical model of Pressure System

The process consists of a pressure vessel that shown by Fig. (1), which has an internal pressure P. The inlet stream has flow Q₁ and pressure P₁ . The outlet stream contains a control valve which is connected to a controller, which has a pressure P₂ and outlet flow Q₂. A dynamic model of the process is obtained from the component material balance under the following assumptions: -

1. The system considered is isotherm.
2. Flow resistance is linear.
3. Air considered is ideal gas.
4. Low pressure in the vessel (so volume is constant).

Applying the principle of the conservation of mass to the system shown in Fig. (1), the following equations can be written:

Input mass flow rate – Output mass flow rate = Accumulation

$$Q_1(t) - Q_2(t) = C \frac{dP}{dt}$$

$$Q_1(t) = \frac{P_1 - P}{R_1} , \quad Q_2(t) = \frac{P - P_2}{R_2}$$

$$C \frac{dP}{dt} + \frac{P(t)}{R_2} - \frac{P_2(t)}{R_2} = \frac{P_1(t)}{R_1} - \frac{P(t)}{R_1} \dots\dots\dots (2)$$

$$C \left[\frac{R_1 R_2}{R_1 + R_2} \right] \frac{dP}{dt} + P(t) = \left[\frac{R_2}{R_1 + R_2} \right] P_1(t) + \left[\frac{R_1}{R_1 + R_2} \right] P_2(t) \dots\dots\dots (3)$$

$$\tau \frac{dP}{dt} + P(t) = K_{P1} P_1(t) + K_{P2} P_2(t) \dots (4)$$

$$\tau = C \left[\frac{R_1 R_2}{R_1 + R_2} \right], \quad K_{P1} = \frac{R_2}{R_1 + R_2}, \quad K_{P2} = \frac{R_1}{R_1 + R_2}$$

Taking Laplace transform for the Eq. (4):

$$P(s) = \left(\frac{K_{P1}}{\tau S + 1} \right) P_1(s) + \left(\frac{K_{P2}}{\tau S + 1} \right) P_2(s) \dots (5)$$

At R₁= 750 (bar.sec.)/kg, R₂= 660 (bar.sec.)/kg, and C= 0.3 kg/bar. The Eq. (5) can be written:

$$P(s) = \left(\frac{0.47}{105S + 1} \right) P_1(s) + \left(\frac{0.53}{105S + 1} \right) P_2(s) \dots (6)$$

2.2-Analysis and Stability of Pressure Control System (1)

In this section consideration will be given to the mathematical analysis of the control loop as a whole, and to the determination of the dynamic response of

the vessel's pressure as a controlled variable following an input disturbance to the system. Consider the block diagram of the closed loop for the pressure control shown in the Fig. (2). The next step is to determine the overall transfer functions relating the vessel's pressure as a controlled variable to the desired value and to the inlet stream's pressure as a load variables. The overall transfer function of the pressure closed loop can be written:

$$P(s) = \frac{G_C(s)G_V(s)G_P(s)}{1 + G_C(s)G_V(s)G_P(s)G_m(s)} P_{SP}(s) + \frac{G_L(s)}{1 + G_C(s)G_V(s)G_P(s)G_m(s)} P_1(s) \dots\dots (7)$$

Where $G_V(s) = K_V$, $G_m(s) = K_m$, $G_P(s) = \left(\frac{0.53}{105S+1} \right)$, $G_L(s) = \left(\frac{0.47}{105S+1} \right)$ and $G_C(s)$ is a transfer function of controller.

For a proportional controller the transfer function is the proportional sensitivity, K_C . For a regulator-loop system by introducing step change in the load variable, the inlet pressure (P_1) where Eq. (7) is used and simplified to:

$$P(s) = K_{R1} \Delta P_1 \left[\frac{1}{S(\tau_{R1}S + 1)} \right] \quad (8)$$

$$\text{where } K_{R1} = \frac{K_{P1}}{K_m K_V K_C K_{P2} + 1} \text{ and}$$

$$\tau_{R1} = \frac{\tau}{K_m K_V K_C K_{P2} + 1}$$

Inversely transforming

$$P(t) = K_{R1} \Delta P_1 \left(1 - e^{-t/\tau_{R1}} \right) \quad (9)$$

$$\text{at } t \rightarrow \infty, P(\infty) = \lim_{S \rightarrow 0} (S \cdot P(s)) = K_{R1} \Delta P_1,$$

where $P(\infty)$: ultimate value

$$\text{offset} = P(\infty) - P_{SP}$$

$$\text{offset} = K_{R1} \Delta P - 0 = K_{R1} \Delta P$$

Similarly for a servo-loop system by introducing step change in the pressure' set point, the pressure response and offset are:

$$P(t) = K_{S1} \Delta P_{SP} \left(1 - e^{-t/\tau_{S1}} \right) \dots\dots\dots (10)$$

$$\text{at } t \rightarrow \infty, P(\infty) = \lim_{S \rightarrow 0} (S \cdot P(s)) = K_{S1} \Delta P_{SP}$$

$$\text{offset} = P_{SP} - P(\infty)$$

$$\text{offset} = \Delta P_{SP} - K_{S1} \Delta P_{SP} = \Delta P_{SP} (1 - K_{S1})$$

$$\text{where } K_{S1} = \frac{K_{P2} K_V K_C K_m}{1 + K_{P2} K_V K_C K_m},$$

$$\tau_{S1} = \frac{\tau}{1 + K_{P2} K_V K_C K_m}$$

To test the stability of pressure control system is determined only by the denominator of the transfer function of

the closed loop, and the effective characteristic equation is:

$$G_{OVL} = G_C(s)G_V(s)G_P(s)G_m(s) \dots\dots\dots(11)$$

$$1 + G_{OVL} = 0$$

Similarly for a proportional-integral (PI), and proportional-integral- derivative (PID) controllers, the vessel's pressure response and offset of a regulator-loop can be written:

PI controller

$$P(t) = \frac{\Delta P K_{PI} \tau_I}{K_{R2}} \left[\frac{EXP\left(\frac{-\zeta t}{\tau_{R2}}\right)}{\tau_{R2} \sqrt{1-\zeta^2}} \text{Sin}\left(\frac{\sqrt{1-\zeta^2}}{\tau_{R2}} t\right) \right] \dots\dots\dots (12)$$

offset = 0 when $t \rightarrow \infty$

Where $K_{R2} = K_C K_V K_{P2} K_M, \tau_{R2} = \sqrt{\frac{\tau \tau_I}{K_{R2}}}$,

$$\zeta = \frac{1 + K_{R2} \sqrt{\tau_I}}{2 \sqrt{\tau} K_{R2}}$$

PID controller

$$P(t) = \frac{\Delta P K_{PI} \tau_I}{K_{R3}} \left[\frac{EXP\left(\frac{-\zeta t}{\tau_{R3}}\right)}{\tau_{R3} \sqrt{1-\zeta^2}} \text{Sin}\left(\frac{\sqrt{1-\zeta^2}}{\tau_{R3}} t\right) \right] \dots\dots\dots (13)$$

offset = 0 when $t \rightarrow \infty$

Where $K_{R3} = K_C K_V K_{P2} K_M, \tau_{R3} = \sqrt{\frac{\tau \tau_I + K_{R3} \tau_I \tau_D}{K_{R2}}}$,

$$\zeta = \frac{\tau_I + K_{R3} \tau_I}{2 K_{R3} \tau_{R3}}$$

EXPERIMENTAL WORK

1- Description of The Experimental Equipment

A laboratory pressure/flow control system is consisting of pressure vessel and control devices. The system is show in Fig. (1). The capacity of the pressure vessel is 0.35 m³ where the pressure is indicated by a indicator fitted at the top of the vessel. The pressure vessel having inlet, outlet and drain. Dimensions of the cylindrical pressure vessel are 0.5 m inside diameter and 1.8 m height. Compressed air supplied to the pressure vessel at pressure 2.5 barg and with a maximum flow rate of a 20 m³/hr at standard conditions. Two rotameter having stainless steel float with range of flow (1–20 m³/hr) of air at about 20°C each were employed for measuring the flow rate of the inlet and outlet streams.

The outlet air flow rate is controlled using pneumatically operated control valve. The orifice plate and differential

cell are used to measure the pressure of the outlet air from the pressure vessel. Also, an orifice element and differential cell are used to measure the flow rate of the outlet air from the system. The pressure and flow rate of the air transmitted whose output is a current in the range of 4-20 mA. This current is fed to an electronic controller where the signal current is compared with a value set up on the controller. A control signal in the range 4-20 mA resulting from this comparison is supplied to an auto/manual station and hence, as a 4-20 mA signal, to a current/pressure (I/P) converter which in turn supplies an air pressure signal in the range 3-15 psig to operate the control valve. The air used for the instruments is filtered and regulated by air filter/regulator with pressure gauge. The maximum pressure of air inlet to the filter 150 psig and the maximum pressure of the air outlet were 20 psig and then the air entered the transducer (I/P).

2-Experimental Arrangement

The runs were carried out for the pressure of vessel, for proportional control run, the equipment was first prepared as follows: -

1. Pressure vessel was supplied with air from compressor.
2. Adjust the air supply to control instruments using the regulator to give a pressure of 21 ± 1 psig.
3. Switch off the integral and derivative actions and set the system on automatic control.
4. Set the controller set point to 60% on the dial corresponding to 2 barg.
5. Wait until the pressure value of the system is steady.
6. The inlet pressure stepped up from 2 barg to 2.5 barg and then pressure of vessel recorded with respect the time every 10 seconds.
7. Repeat the same steps for proportional- integral and proportional- integral -derivative control.

RESULTS AND DISCUSSION

The response of the pressure control system was obtained by a step change in the pressure of the inlet stream. The response of Eq. (9) is shown in Fig. (3) for different values of controller gains (K_c). It will be seen that for load changes the initial value of the slope of the response curve is not dependent on

the value of K_C ; this is because the controller dose not begin to act until the load change has started to take effect. The initial rate of change (dp/dt at zero time) is given by $(\Delta PK_{P1}/\tau)$. The final value is offset from zero (the set point value) by $(K_{R1}\Delta P)$. Offset following a change in an input variable is a fundamental property of proportional control. It can be seen that the magnitude of the offset is inversely proportional dependent on magnitude of the overall gain $(K_m K_v K_{P2} K_C)$.

All gains are constant except the (K_C) , hence the offset is inversely determined by the value of the proportional control, increasing the controller gain decrease the value of (K_{R1}) and thus reduces the offset, as shown in Fig.(3). The transient part of the solution is determined by the exponential term. The time for the system to reach the steady state is then determined by the effective time Constant (τ_{R1}) . As with the offset, the effective time constant is inversely dependent on the $(K_C K_m K_{P2} K_v)$ and so on the proportional controller gains K_C . The larger the K_C , the smaller is the effective time constant of the system and so the faster is the time for the system to reach the steady state and so recover from

the disturbance. The root of the characteristic equation are negative real, the system is stable and non- oscillatory.

The response of Eq.(12) is shown in Fig.(4) for different value of K_C . This Figure shown increasing K_C or a fixed value of τ_i improves the response by decreasing the maximum (peak) deviation and also by damping the response by in increased value of damping factor (ζ) . For a fixed value of K_C (Fig.5), a decreasing in τ_i decreasing the maximum deviation and period but makes the response more oscillatory as damping factor is now decreased. The overall effect is relatively small in view of the wide range of variation of the parameters. The proportional – integral control become oscillation at a lower gain, the stability decreasing as the integral time is reduced. An added integral action the offset is eliminated. We should find that for value of $K_C \leq 2.84$ the system response become oscillatory.

The response of Eq. (13) is shown in Fig. (6) for different value of τ_D . For a fixed value of K_C and τ_i , the derivation action will increase the stability and speed of response and permit the use of a higher proportional gain and a lower

integral time .The addition of derivation active to proportional – integral control dose not increase the order of the equation and thus the response is basically of the some form as that for proportional – integral control of same conditions.

The comparison of response between the theoretical and experimental case for different actions are show in Fig. (7) to (9). It can be seen that the theoretical response is the faster then experimental response and theoretical response has a small offset. These Being due to other small lags such as those in measurement device and control value which are always present in a experimental case.

CONCLUSIONS

The following conclusions were drawn from the preceding discussion of the different control actions.

1. The proportional (P) control may be considered as the basic case and results in a response showing a large maximum deviation. Proportional-integral controller (PI) shows that the offset is reduced as K_C increased and

improvement in steady-state performance is obtained.

2. The Proportional-integral-derivative (PID) controller is essentially a compromise between the advantages and disadvantages of PI controller and advantages of PD controller. The three terms of property tuned PID controller can work together to provide rapid response to error, eliminate offset and minimize oscillation in the measured process variable.
3. The theoretical response is faster than the experimental response due to lags of the control valve and measurement elements.
4. The pressure control system is stable for all conditions and different control action because the real parts of roots of characteristics equation are negative but the response at PID controller is oscillatory stable.

REFERENCES

1. Hougén, J. O., “Experimental Studies Measurements and Control Applications”, ISA, 1979.

2. Fletcher, I., Arden, W.J.B. & Cox, C.S., 'Multivariable Control Strategies applied to a Gas Pressure Reduction Station', 4th International Symposium on 'Applications of Multivariable System Techniques', Bradford University, ISBN, pp128-136, 1990.
3. French, I. G., Fletcher, I., and Ng, S., 'Control of a Gas Scrubber Process', Proc. International Conference 'Control 91', Heriot-Watt University, pp596-601, 1991.
4. Fletcher, I., Burn, K., Arden, W.J.B. 'Fuzzy Control of a two-stage High Pressure Gas Reduction Station', Int. Conference on Applications of Multivariable System Techniques, University of Bradford, April 1998.
5. Harris, J., : 'Fuzzy Logic Applications in Engineering Science', Springer/ Netherlands, pp. 136-150, 2006.
6. Zlokovitz, R., "Development of Predictive Control Hardware and Adaptive Algorithm for District Regulators , Gas Research Institute research program, 1989.
7. Zlokovitz, R., Randy, G., "Optimizing Low Pressure District Regulator Stations" , Gas Research Institute research program, 1990.
8. Alessandro, Pontremoli, "Modeling and Control of a Paper Dryer Section Using Modelica", Master thesis, Lund Institute of Technology, November, 2000.
9. Luyben, W., " Autotuning of PID Controllers", Spring-Verlag, London limited, pp. 167-173, 2006.
10. Johan, Gagner, "Adaptive Realtime Control of a Nonlinear Throttle Unit", Master thesis, Lund Institute of Technology, February, 2000.
11. John, A., "Gas/Liquid Phase Separator With Improved Pressure Control", United State Patent No. 2003/0201187A1, October, 2003.
12. Bernd, R., Tobios, E., Tomas, M., and Maiaberg, U., " Pressure Control Devise and Method for Programmer Controlled Actuation of a Pressure Regulating Mechanism", United State Patent No. 2003/0149519A1, Aug., 2003.
13. Frank, R., "Gas Pressure/Flow Control and Recovery System" United State Patent No.2003/0136176A1, 2003.

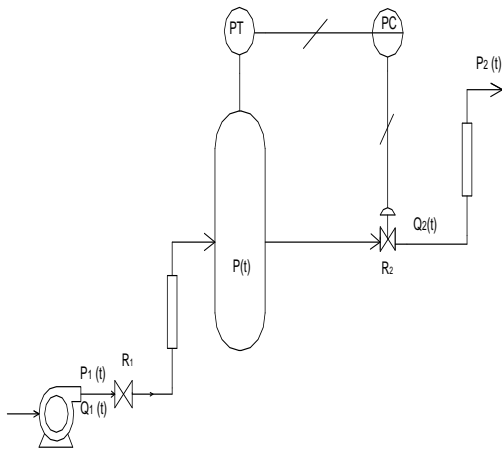

Figure (1) Schematic diagram of experimental pressure control system.

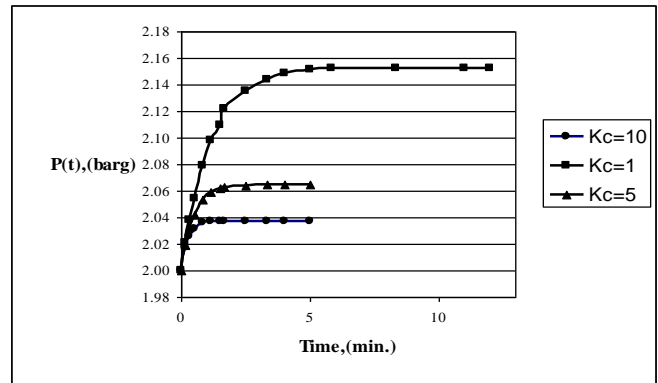

Figure (3) Experimental system response of P-controller to step change in inlet pressure (P₁) at different K_C.

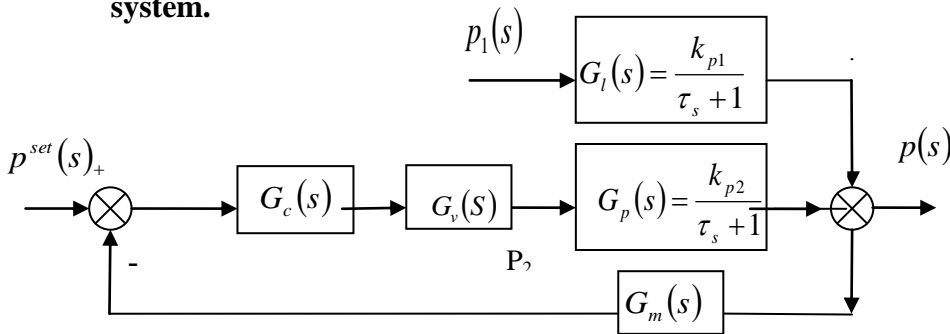

Figure (2) Block diagram of pressure control system.

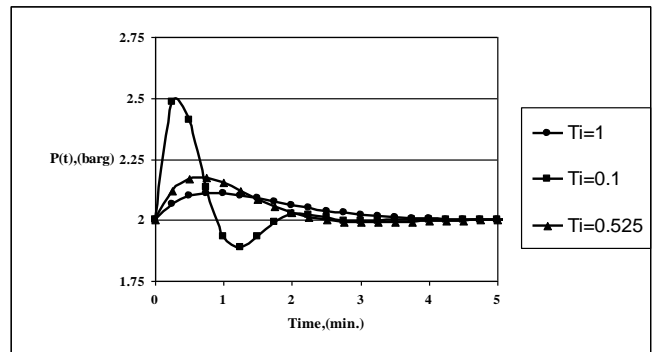

Figure (4) Experimental system response of PI-controller to step change in inlet pressure (P₁) at K_C= 5 with different τ_I(min.).

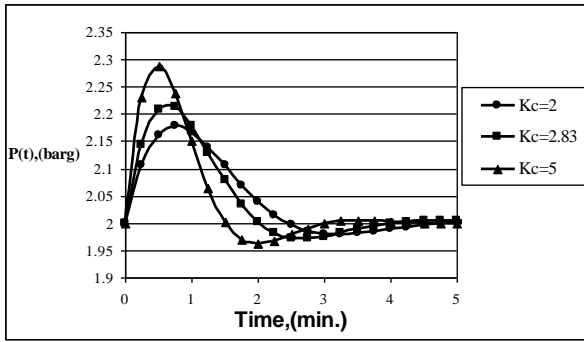

Figure (5) Experimental system response of PI-controller to step change in inlet pressure (P_1) at $\tau_I= 0.25$ min. with different K_C .

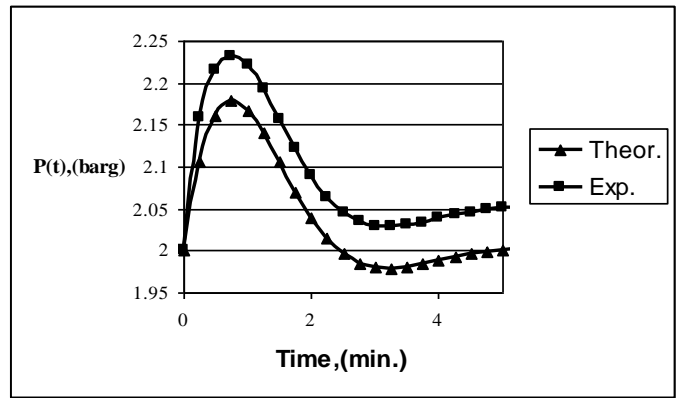

Figure (8) Comparison between the theoretical and experimental pressure response at PI-controller.

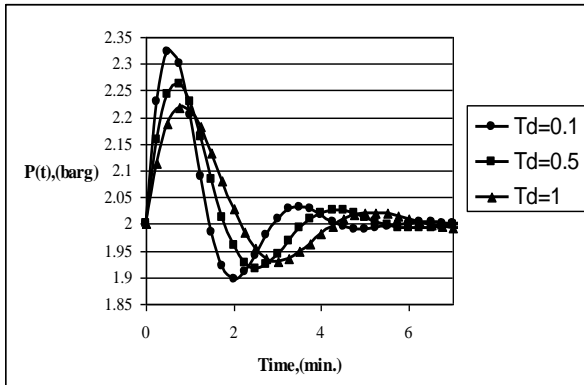

Figure (6) Experimental system response of PID-controller to step change in inlet pressure (P_1) at $K_C=5$, $\tau_I= 1$ min. with different τ_D (min.).

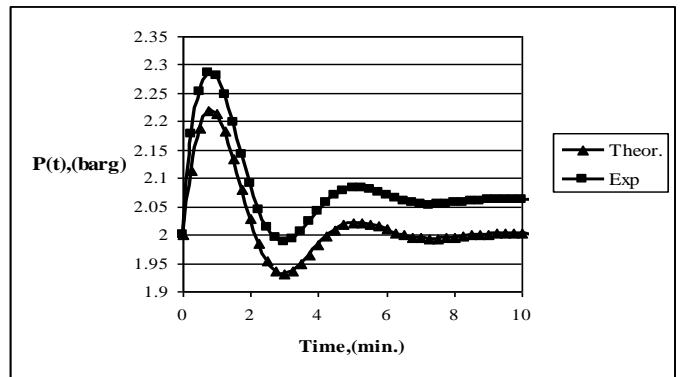

Figure (9) Comparison between the theoretical and experimental pressure response at PID-controller.

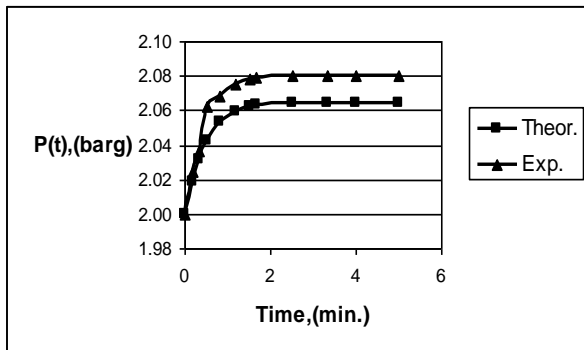

Figure (7) Comparison between the theoretical and experimental pressure response at P-controller

تحليل الأستقرارية وتصميم منظومة السيطرة على الضغط

السيد لقمان عزيز عبدالكريم

مهندس

قسم الهندسة الكيماوية-جامعة بغداد

د. سلام الداوري

استاذ مساعد

قسم الهندسة الكيماوية-جامعة تكريت

د. دريد فاضل أحمد

مدرس

الخلاصة

تم دراسة الأداء وتحليل الأستقرارية لمنظومة السيطرة على الضغط لعدة أنواع من أجهزة التحكم. تم تطوير الموديل الرياضي لمنظومة السيطرة ومن ثم دراسة السلوك الديناميكي لنظام السيطرة وذلك بتسليط تغيير درجي. أظهرت النتائج ان استجابة الموديل الرياضي هو أسرع من استجابة العملي وذلك لوجود ثابتا الزمن لصمام السيطرة وجهاز قياس الضغط. تناول البحث تحليل استقرارية منظومة السيطرة وتم الاستنتاج بان النظام مستقر لجميع أنواع أجهزة التحكم ولكل الظروف التشغيلية. كما بينت النتائج بتحسن الاستجابة بوجود جهاز تحكم من نوع تناسبى-تكاملى-تفاضلى وذلك لزوال الحيد بوجود التكاملى وأكثر استقرارية بوجود التفاضلى مما جعل الاستجابة أسرع بزيادة الكسب التناسبى مقارنة مع الأنواع الأخرى من أجهزة التحكم.

الكلمات الدالة: سيطرة على الضغط، الأستقرارية، مسيطر تناسبى-تكاملى-تفاضلى.