MESH SIZE EFFECTS IN NONLINEAR DYNAMIC 3D-ANALYSIS OF REINFORCED CONCRETE BEAM UNDER IMPACT LOADS

Ammar Saleem K.

Assistant Lecturer

Civil Eng. Dept.-University of Tikrit

ABSTRACT

The investigation into the effect of mesh size in nonlinear 3D-analysis of reinforced concrete beam under dynamic load presents in this paper. The behavior of reinforced concrete beam under dynamic loads are supported by intensive numerical simulations, and the effect of various parameters on the results is of great interest. Finite element simulations were performed in the nonlinear dynamic domain with modified concrete and steel constitutive models. To eliminate the dependence of the computed results on the mesh size, a procedure for calculating the ultimate tensile strain of concrete was developed and implemented into nonlinear dynamic analysis. The proposed model gives good agreement with the experimental results. In particular, the new model can be used effectively with relatively mesh size in reasonable accuracy.

KEYWORDS

Mesh size, Dynamic Analysis, Nonlinear Analysis, Impact loads.

INTRODUCTION

Although many researches have been conducted about the effect of element size (mesh size) on the accuracy of results for linear or nonlinear structures

under static load, but it is still rare for dynamic load analysis of structures.

Cervera et al., 1988^[1], made analytical studies to show the effect of mesh size to the result of analysis of plates and shells simply supported or clamped at all edges. From a careful

analysis of these and other results it appears wise to limit the aspect ratio (span of plate to its thickness) of the individual 20-node brick elements to a maximum of about 25 when bending action predominates and when adequate computational precision is available.

Krauthammer and Otani, 1997 [2], studied ten different cases of analysis of reinforced concrete structures, each with different reinforcement details and with coarse and fine mesh resolution on the numerical simulations. They showed the deformations by fine mesh were larger than those by the coarse mesh. The difference in maximum displacement between the coarse and the fine meshes decreased gradually depended on the steel percent. This indicated that the higher degree of resolution of the fine mesh had incrementally less effect on the structure behavior due to the enhanced strength provided by the additional steel, although the differences in displacements between the fine and the coarse meshes were small for big amount of steel in concrete. Comparison of the steel stresses between the course and the fine meshes revealed that there was relatively good agreement between the maximum

longitudinal stresses, but there were large discrepancies when transverse stresses were involved in the shear and radial reinforcements. This indicated that the 'lumping' of such reinforcement in the coarse mesh did not accurately capture the correct state of stresses.

Finite element simulations were performed in this paper to the nonlinear dynamic domain with modified concrete and steel constitutive models. To eliminate the dependence of the computed results on the mesh size, a simple procedure for calculating the ultimate tensile strain of concrete was developed and implemented into nonlinear dynamic analysis. The proposed model gives good agreement with the experimental results. In particular, the new model can be used effectively with relatively mesh size in reasonable accuracy.

MATERIAL MODELING OF REINFORCED CONCRETE

A large Variety of models have been proposed in the last three decades to characterize the stress-strain and failure of reinforced concrete material. All these models have certain inherent advantages and disadvantages, which depend, to a

large extent on their particular application [3].

A perfect plasticity model is often used to account for the plastic flow of concrete before crushing. The description of such model requires the yield criterion and a flow rule for the direction of plastic deformation rate vector. Only plastic stress-strain relationship during plastic flow needs to be added to the elastic model. Normality principle determines the direction of inelastic deformation rates. The dependence of yield function on the mean normal stress and the concept of flow rule leads to dilatation near failure usually observed in concrete. The introduction of plastic potential surface and the use of nonlinear relations for concrete before yield have further enhanced its performance.

It's clear from the conclusions drawn in the previous section [1] that any numerical model for reinforced concrete intended for transient analysis should be rate and history depended.

A strain-rate-sensitive elasto-viscoplastic model introduced by Bicanic and Zienkiewicz [4] which is modification of Przyrna's elasto-viscoplastic model. Modified models, for shells by Liu [5],

and a three-dimensional brick-element given by Cervera et al. [1] which takes fluidity parameter as dependent on the elastic strain rate. More recently a two-dimensional model has been introduced by Beshara [6]. In this paper the Cervera Model has been used.

Three-Dimensional Model of Concrete

The yield and failure surface change during inelastic straining depending upon the accumulated damage, expressed as visco-plastic work W_p given by:

$$W_p = \int_0^t \sigma^T \dot{\varepsilon}_{vp} dt \quad \dots\dots\dots(1)$$

The uniaxial cylinder compressive strength of concrete f'_c is taken as a guide. While the stress path remain inside the yield surface, the behavior of concrete is linearly elastic, no visco-plastic work is done and the yield and failure surface remain stationary. When the stress path is outside the yield surface, inelastic straining occurs, and the failure surface shrinks. The failure surface is only a monitoring device to define where failure occurs. When the stress path reaches the failure surface, degradation of material is initiated. The failure surface is no longer considered, and the yield surface begins

to shrinks according to the post-failure dissipated energy as shown in Fig.(1).

The rate of visco-pastic straining is assumed to depend on the rate of elastic strain and on the position of yield surface. The fluidity parameter is related to the elastic strain rate through a related exponential of an effective elastic strain rate

$$\gamma(\dot{\varepsilon}_e) = a_0 (\varepsilon_e^{\text{eff}})^{a_1} \dots\dots\dots(2)$$

where a_0 and a_1 are parameters to be determined experimentally. The effective elastic strain, $\varepsilon_e^{\text{eff}}$, is define as

$$\varepsilon_e^{\text{eff}} = \left(\frac{3J_{2e}}{(1+\nu)^2} \right)^{1/2} \dots\dots\dots(3)$$

where ν is the Poisson's ratio and J_{2e} is the second deviatoric strain invariant. This expression for effective elastic strain has been adopted because deviatoric strains cause most damage to concrete and the effective elastic strain is equal to the uniaxial elastic strain for a uniaxial stress state. The associated visco-plastic flow rule of Perzyna [7] has been used. The cracking concrete behavior used in this paper as used by Abbas et al. [3].

Reinforcing Steel

Concrete as well as the reinforcement are represented with the single element. Perfect bond is assumed between the reinforcement and the surrounding concrete. It is expected that this assumption may introduce some error but its magnitude will be small when the cracks are minor. Each set of reinforcing bar is smeared as a two-dimensional membrane of equivalent thickness as in Fig.2. The layer is assumed to resist only the axial stresses in the direction of the bars. Stresses and the local stiffness matrix for the reinforcement is first evaluated in the local system and then its contribution is added to that of the concrete after global transformation. The elasto-plastic behavior of concrete is incorporated by considering a bilinear stress-strain curve. The curve is assumed to be the same in the tension and compression.

Numerical Applications

1-Simple supported Reinforced Concrete Beam Under Step Load: A reinforced concrete beam subjected to two symmetrically placed point loads applied as step loads. The geometry and loading as shown in Fig.(3). The beam has a

bottom reinforcement of area 12.9 cm^2 . Due to symmetry in geometry and loading, only one-half of the beam was considered. The half span was modeled by five 20-noded brick elements in x-direction, and one brick element in y-and-z-direction (mesh1), with the reinforcing steel simulated by an equivalent layer of thickness 0.85 cm positioned at the lower face of each element. Also, using five brick element in x-direction with one brick element in y-direction and two element in z-direction(mesh2). Mesh3 the same of mesh2 but with three element in z-direction and mesh4 the same of mesh1 but with seven equal length element in x-direction as shown in Fig.4. Also, using Mesh 5 which the same of mesh1 but with two brick element in y-direction, Mesh6 the same of mesh 5 but with two element in z-and y-direction, finally mesh7 with three brick element in y and z-direction. The time step chosen as $1/40$ of the fundamental period. The material properties are shown in table 1. Dynamics response show in Figs.(5 and 6) clearly indicate that the mesh 1 give approximately same results of mesh 4, also, this appear for mesh 2 and mesh 3. fine meshes (mesh 5 ,6 and 7) give smooth

and good result which are always less than coarse meshes.

Fig.(7) shows effect of time step to the dynamic response of beam, it's small and can neglected when $(T/\Delta T)$ between 23 to 40), where T elastic fundamental period and ΔT the time step.

2- Simple supported Reinforced Concrete Beam Under Impulsive Distributed Loads: A reinforced concrete beam subjected to an impulsive load of intensity 0.4218 N/mm^2 .

The geometry and dimensions of the beam is shown in Fig.(8). The beam was doubly reinforced by 774.2 mm^2 steel area upper reinforcement and 1290 mm^2 lower reinforcement. The beam was tested by Seabold as given in Reference^[4] and analyzed by Beshara^[6] and Farag and Leach^[4]. The load time history is shown in Figure(9) . The material properties of the concrete and steel are given in Table(2).

Due to symmetry conditions, only one-half of the beam is considered. The mesh used as described in example 1. The dynamic response is shown in Fig.(10) and Fig.(11). Also, Fig.(12) shows the effect of cracking strain to the dynamic response for mesh1.

3-Clamped Reinforced Concrete Beam under Step Load: A reinforced concrete beam clamped edges subject to two symmetrically placed point loads applied as step loads as in example 1. The geometry, loading, and properties as in example 1.

The dynamic response of this beam with different cracking strain shows in Fig.(13). Fig.(14) shows the dynamic response for different meshes.

Fig.(14) shows big different between mesh 4 and others mesh, this because mesh4 has equal brick element length in x-direction, so the mesh must fine near concentrated load as in other meshes, but this effect not appear in simple supported beam.

4- Clamped Reinforced Concrete Beam Under Impulsive Distributed Loads: A reinforced concrete beam subjected to an impulsive load of intensity 0.4218 N/mm^2 as in example but with clamped edges.

The dynamic response of clamped reinforced concrete beam shown in Fig.(15).

The proposed Formula

Different loads are used for simply supported and clamped reinforced concrete beam with different cracking

strain, and compared for different meshes. These characteristic parameters are controlled by the values of ultimate tensile strain, and the tensile strength of concrete, which show significant effect to the dynamic response of reinforced concrete beam.

For each mesh configuration, the value of ultimate tensile strain, was adjusted so that the computed dynamic response was close to the experimental results.

The analytical study lead to the following suggested equations from regression of the curves for four the examples respectively:

$$e_{tu} = 0.0005 e^{-0.25 bxh/100} \dots\dots(4)$$

$$e_{tu} = 0.00052 e^{-0.23 bxh/100} \dots\dots(5)$$

$$e_{tu} = 0.00049 e^{-0.9 bxh/100} \dots\dots(6)$$

$$e_{tu} = 0.00049 e^{-0.77 b2xh/100} \dots\dots(7)$$

where

e_{tu} Ultimate tensile strain

b width of brick element (beam section in inch)

h height of brick element (beam section in inch)

l length of brick element ($\leq 3 \times b$ and in inch unit)

Comparison Of Results

For example one, the simple supported beam under step load effect, Fig.(5) show the curve obtained by Mesh 2 and 3 approximately similar, also, this appear for mesh 1 and mesh4. For fine mesh (meshs 5, 6, and 7) the curve began smooth and good distributed point. Thus for all meshes the fine mesh lead to decreasing in deflection and periodic time (plastic fundamental period).

This conclusion drawing for example one appear the same for example two, but with small percent effect to both deflection and periodic time.

The cracking strain effect to the dynamic response as show in Fig.(11), indicate the increase of cracking strain lead to decreasing in deflection and small decreasing in periodic time.

For examples 3 and 4 clamped reinforced concrete beam under point and uniform distributed dynamic loads, no relation appear between mesh 1 and mesh 4 nor between mesh 2 and 3. Also mesh 4 for clamped reinforced beam under concentrated load example 3 give very bad results far away from others, this because the mesh must fine near the

point load, this not necessary for simply supported beam as shown above.

The above empirical equation obtained by trial and error, give a good formula to choice the finite element mesh using in nonlinear finite element analysis of reinforced concrete beam under impact loads.

CONCLUSIONS

- 1-The suggested equation for concentrated and uniform distributed loads give helpful for select mesh size to achieve good results.
- 2-As shown in Fig.(7) of example 1 the effect of time step change and decrease and can't consider as good parameter related with mesh size, so for future work a good suggestion to consider the effect of time step as function of plastic period time and changing with time and crack pattern.
- 3-Increase the mesh density near the concentrated load don't show significant effect for simply supported beam but its very important for clamped beam.
- 4-Using fracture energy in the finite element analysis give a good help to choice the mesh size.

REFERENCES

- 1- Cervera, E., Hinton, E., Bonet, J., and Bicanic, N., "Nonlinear Transient Dynamic Analysis of 3-D Structures- A Finite Element Program for steel and reinforced concrete materials ", In Numerical Methods and Software For Dynamic Analysis Of Plates and Shells, Hinton E. (ed), Pineridge Press Ltd., pp.320-504, 1988.
- 2-Krauthammer, T, Otani, R. K., " Mesh, Gravity and Load Effects on Finite Element Simulations of Blast Loaded Reinforced Concrete Structures", Computers and Structures, Vol.63, No.6, pp. 1113-1120, 1997.
- 3-Abbas, H., Gupta, N. K., Alam, M., "Nonlinear Response of Concrete Beams and Plates Under Impact Loading", International Journal of Impact Engineering, 30, pp.1039-1053, 2004.
- 4-Farag, H. M., Leach, P., "Material Modeling for Transient Dynamic Analysis of Reinforced Concrete Structures", International Journal for Numerical Methods in Engineering, 39, pp.2111-2129, 1996.
- 5-Liu, G. Q., "Nonlinear and Transient Finite Element Analysis of General Reinforced Plates and Shells", Ph.D. Thesis, Department of Civil Engineering, University College of Swansea, 1985.
- 6-Beshara, F. B., "Nonlinear Finite Element Analysis of Reinforced Concrete Structures Subjected to Blast Loading", Ph.D. Thesis, City University, London, 1991.
- 7-Perzyna, P., "Fundamental Problem in Visco-Plasticity", Advance Applied Mechanics, vol.o, pp. 243-377, 1966.

Table(1) Material properties for simply supported reinforced concrete beam.

1. Concrete	
Young's modulus	42059 (N/mm ²)
Poisson's ratio	0.2
Ultimate compressive stress	25.8 (N/mm ²)
Ultimate compressive strain	0.0035
Cracking stress	6.3 (N/mm ²)
Mass density	0.2 E-8 (N.sec ² /mm ⁴)
2.Steel	
Young's modulus	206800 (N/mm ²)
Yield stress	303.4 (N/mm ²)
Fluidity parameters	a ₀ =1.539 a ₁ =0.971

Table(2) Material properties for Simply supported reinforced concrete beam under impulsive distributed load.

1-Concrete	Young's modulus	24133 (N/mm ²)
	Poisson's ratio	0.17
	Ultimate compressive stress	27.49 (N/mm ²)
	Ultimate compressive strain	0.0035
	Cracking stress	2.777 (N/mm ²)
	Mass density	0.24E-8(N.sec ² /mm ⁴)
2-Steel	Young's modulus	203000 (N/mm ²)
	Yield stress	480 (N/mm ²)
	Fluidity parameters	a ₀ =1.539 a ₁ =0.971

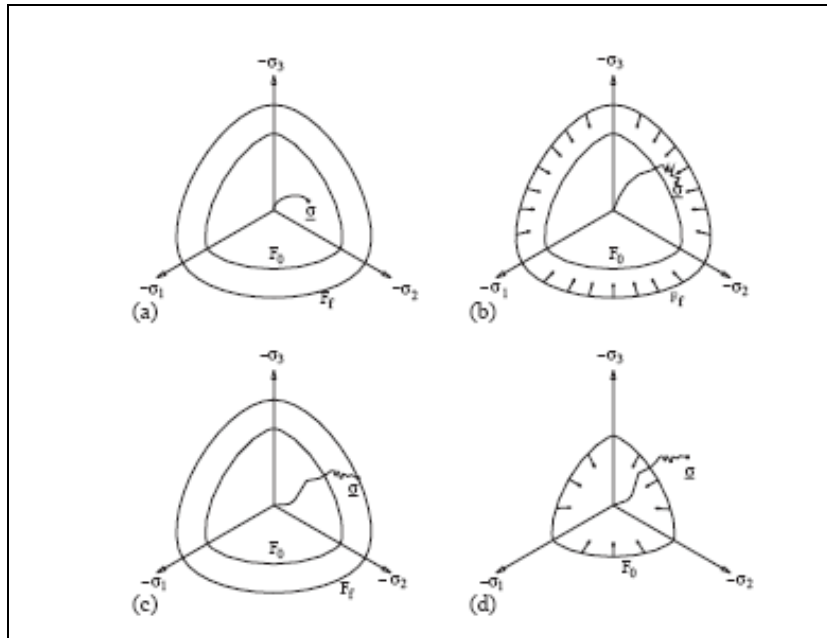

Fig.1:- Yield and failure surface of concrete. (a) Linear elasticity (No change in F_0 and F_f); (b) elastovisco-plasticity (F_0 constant and F_f shrinkage); (c) failure; and (d) post failure (F_0 shrinking).

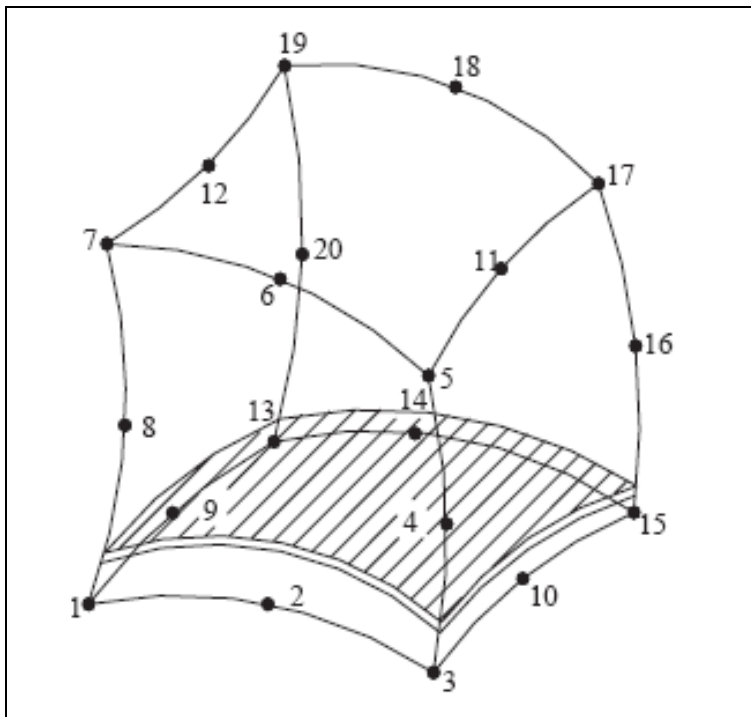

Fig.2 : Reinforcement represented as smeared layer

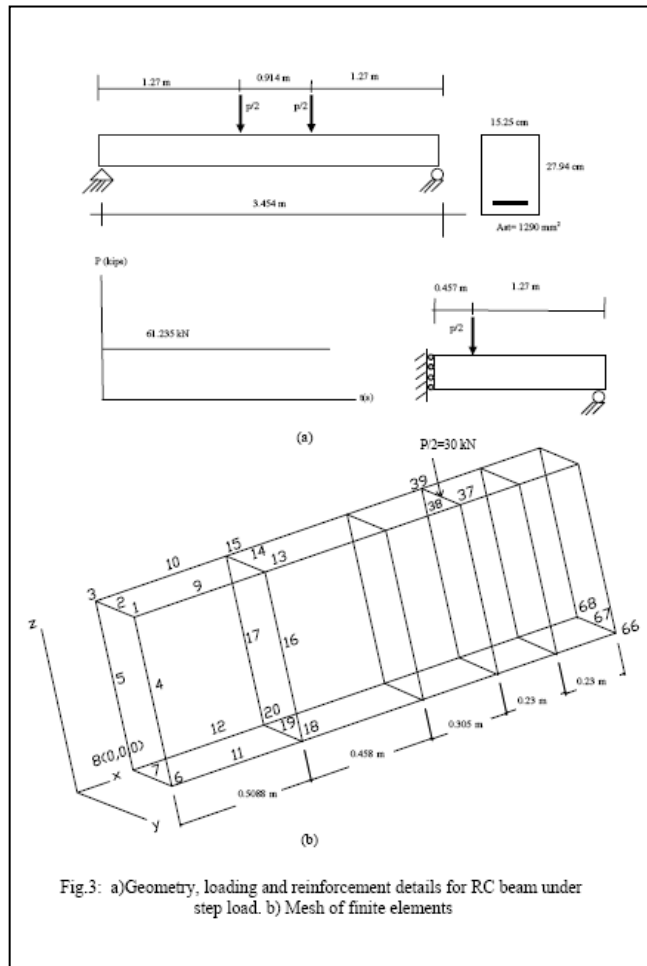

Fig.3: a)Geometry, loading and reinforcement details for RC beam under step load. b) Mesh of finite elements

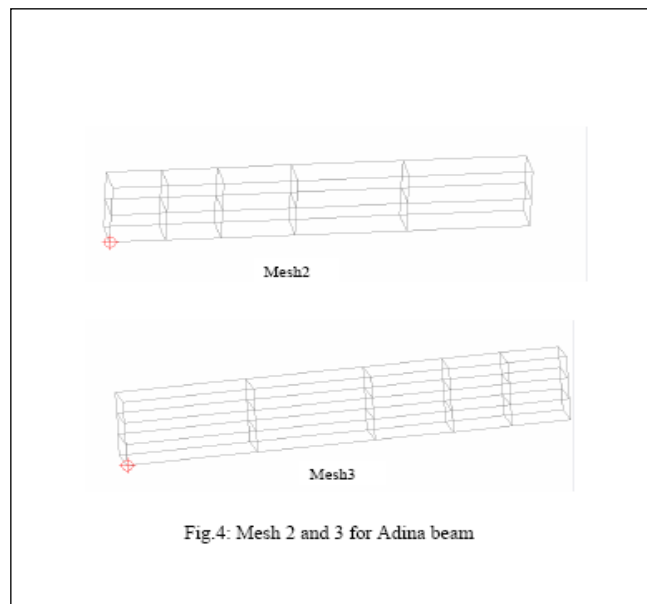

Fig.4: Mesh 2 and 3 for Adina beam

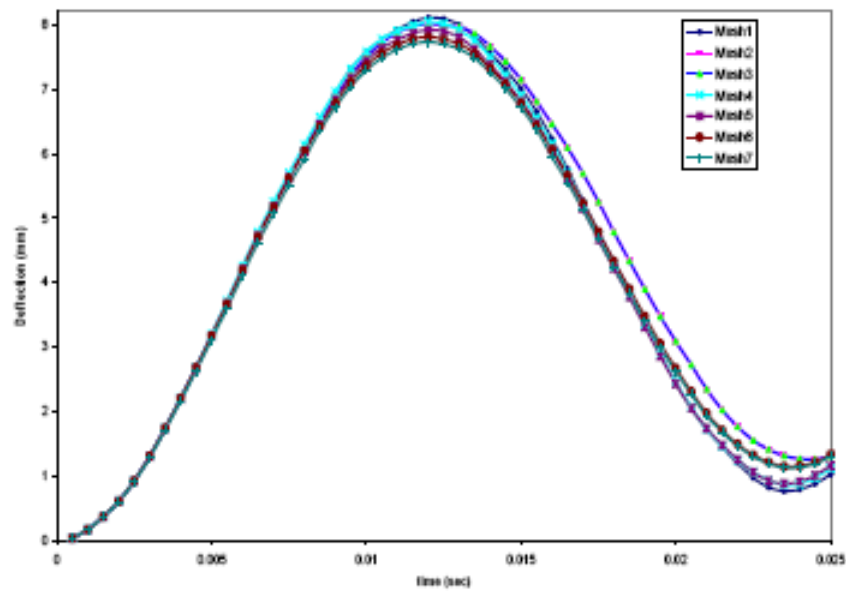

Fig.(5) Dynamic response for Adina beam (interval 1)

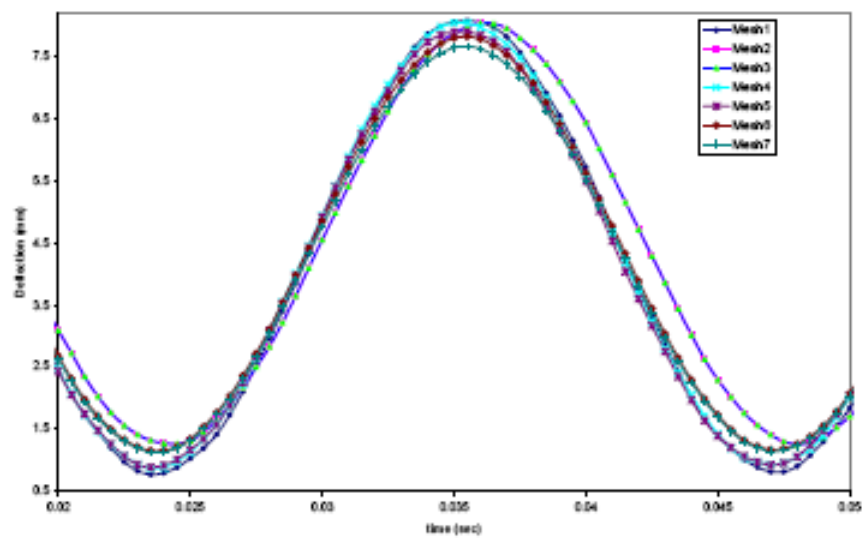
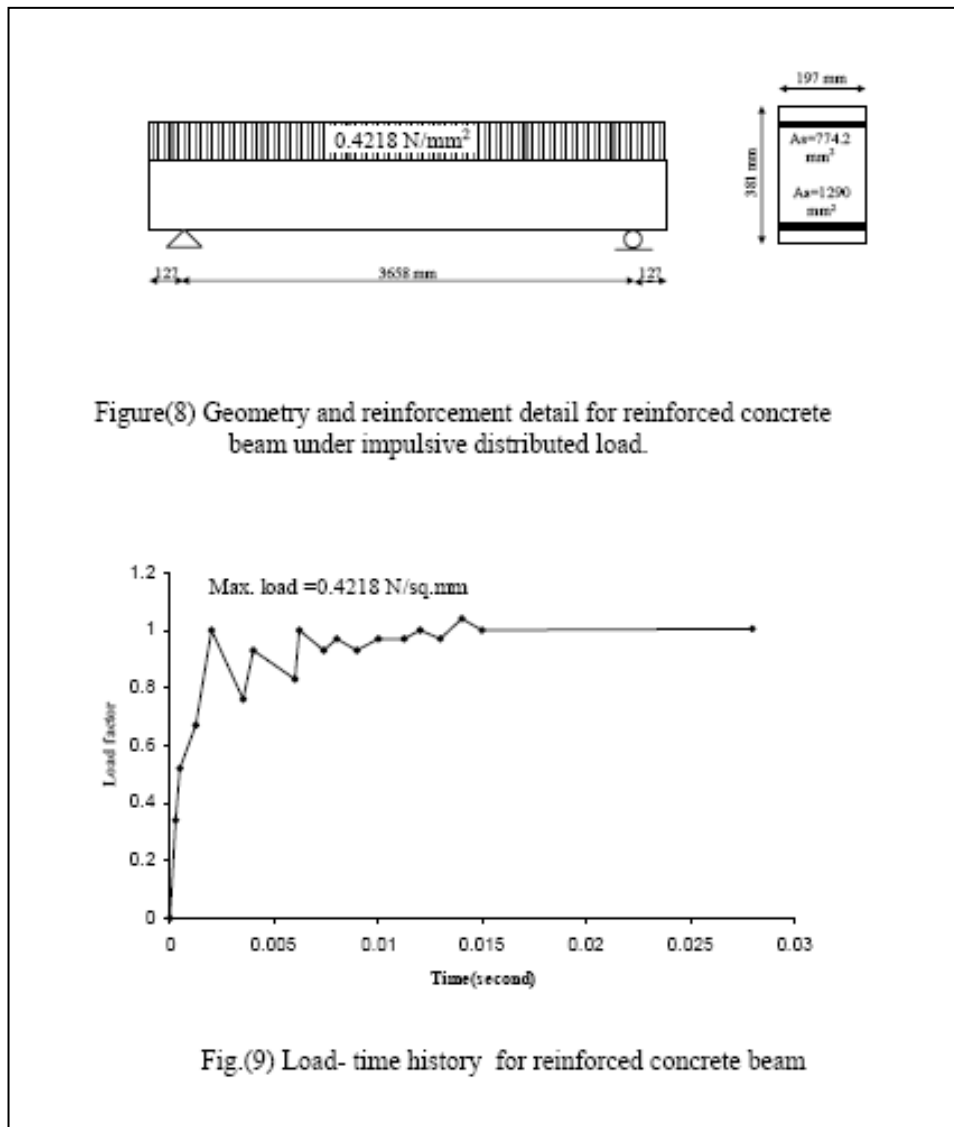
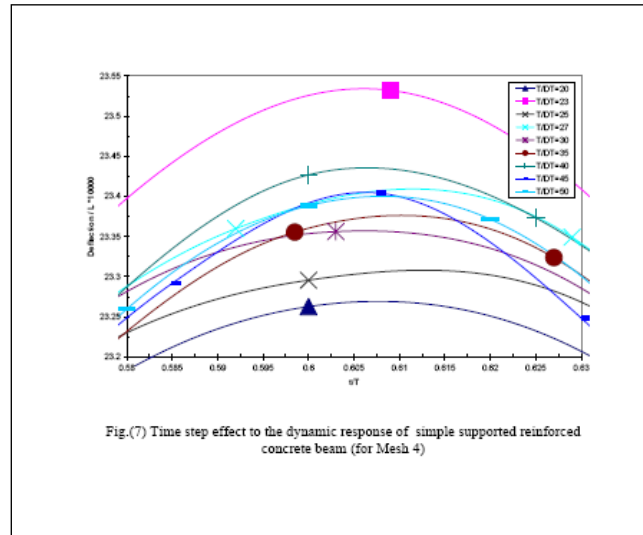

Fig.(6) Dynamic response for Adina beam (Interval 2)



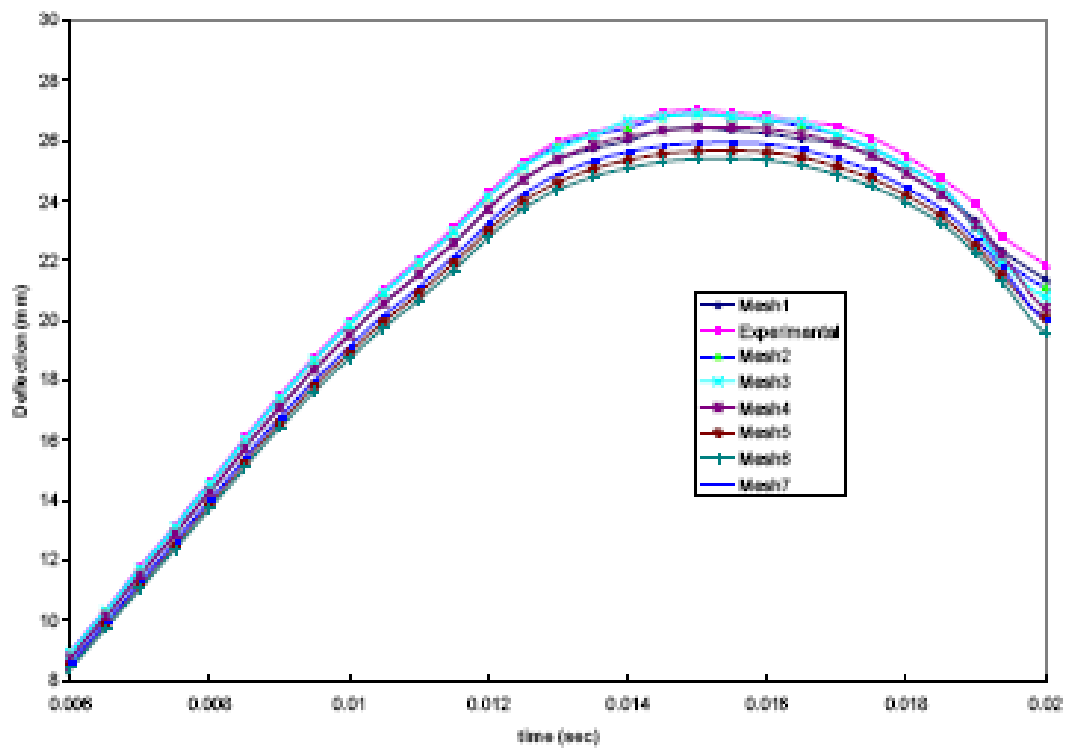

Fig.(10) Dynamic response of reinforced concrete beam (interval 1)

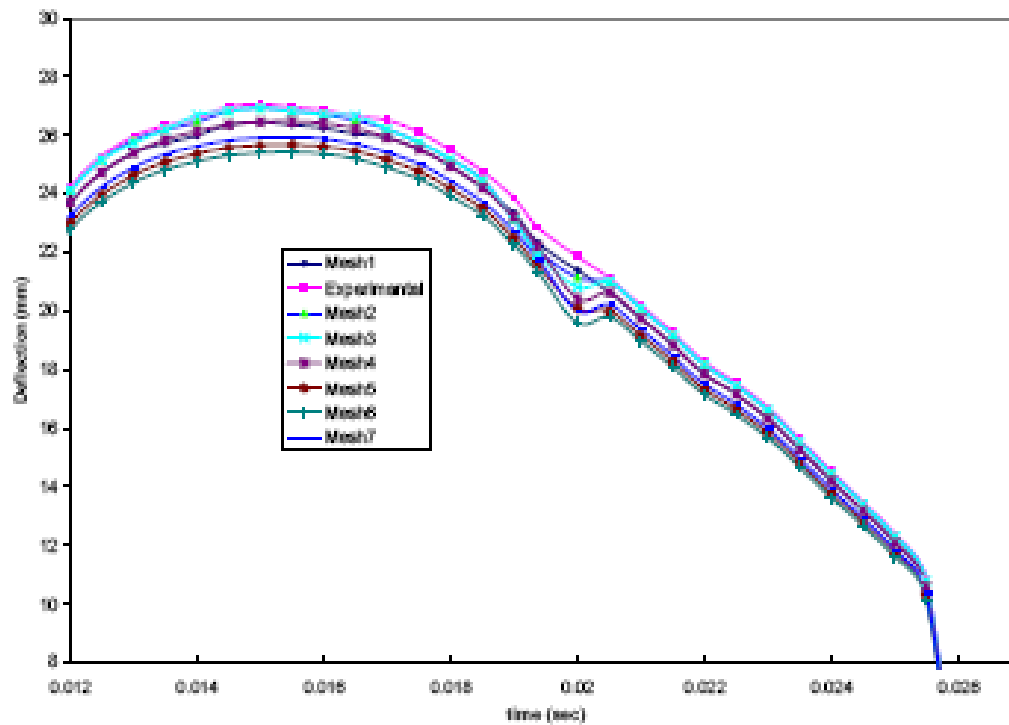

Fig.(11) Dynamic response for reinforced concrete beam (interval 2)

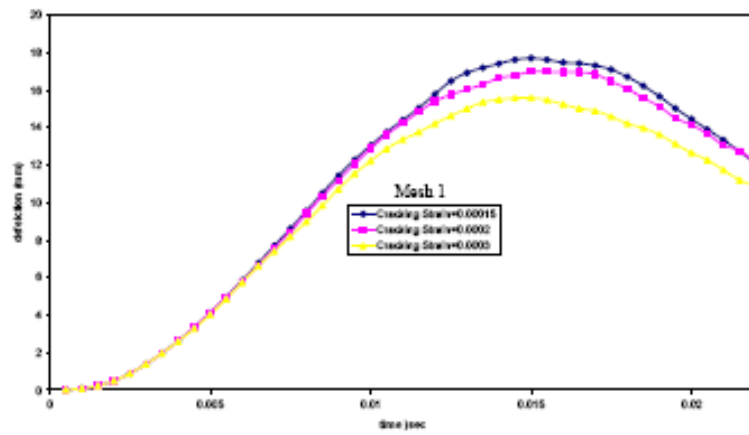

Fig.(12) Dynamic response of reinforced concrete beam with different cracking strain

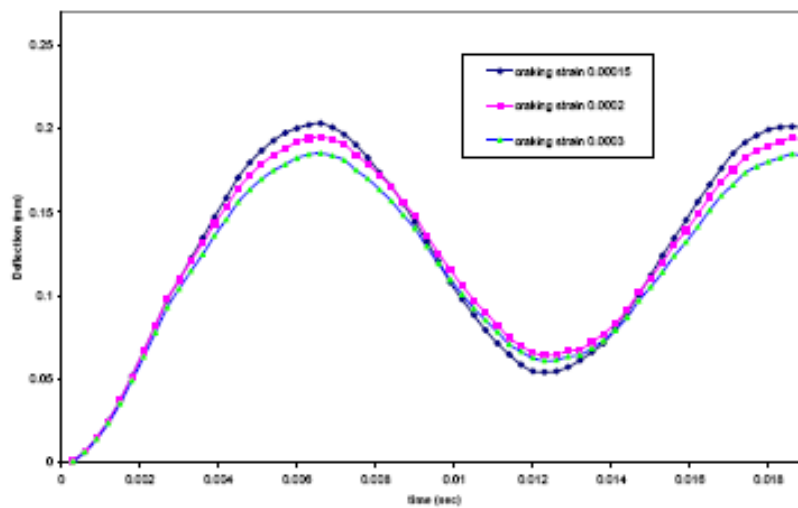

Fig.(13) Cracking strain effect for dynamic response clamped reinforced concrete beam (mesh6 using here).

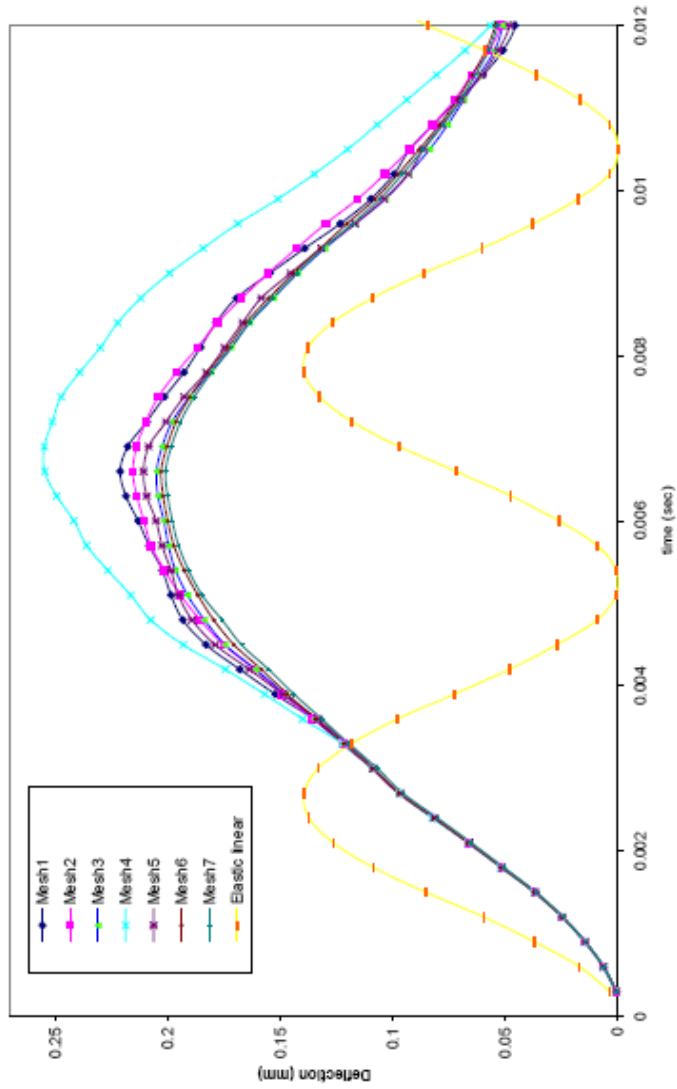

Fig.(14) Dynamic response for clamped reinforced concrete beam

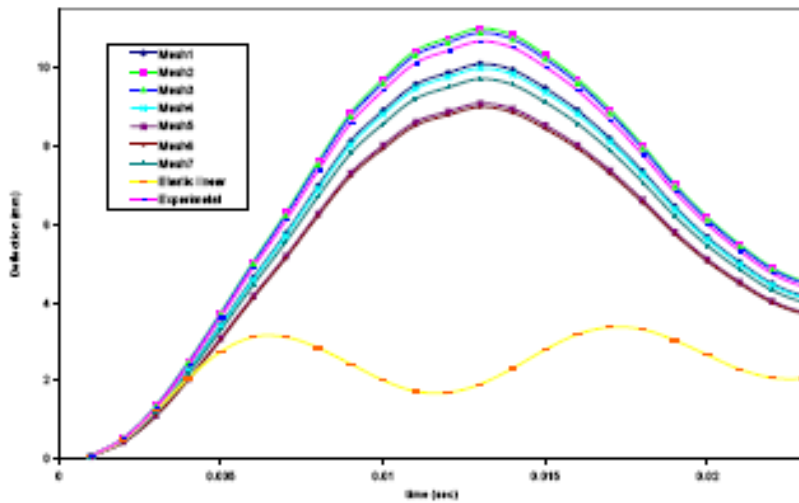

Fig.(15) Dynamic response of clamped reinforced concrete beam under U.D.L

تأثير حجم العنصر في التحليل اللاخطي الديناميكي للأعتاب الكونكريتية المسلحة تحت تأثير أحمال صدمية

عمار سليم خزل

مدرس مساعد

قسم الهندسة المدنية-جامعة تكريت

الخلاصة

استقصاء تأثير حجم العنصر (mesh size or element size) في التحليل اللاخطي ثلاثي الأبعاد للعتبات الخرسانية المسلحة تحت تأثير أحمال ديناميكية تم دراسته في هذا البحث. تم دراسة التمثيل العددي لتصرف الأعتاب الكونكريتية المسلحة مع إدخال تأثير عوامل مختلفة باستخدام العناصر المحددة لتمثيل التصرف اللاخطي الديناميكي مع موديل معدل للكونكريت وحديد التسليح. لكي يتم حذف تأثير اعتماد النتائج على حجم العنصر فإن خطوات مبسطة تم اعتمادها تعتمد انفعال الشد الأقصى للكونكريت وتم تطويرها من نموذج ثنائي البعد الى نموذج لاخطي ثلاثي البعد. الموديل المقترح أعطى نتائج جيدة مقارنة بالنتائج العملية المتوفرة. لذلك فإن النموذج المقترح يمكن اعتماده للحصول على حجم العنصر حسب نوع الإسناد ونوع التحميل لكي يعطي نتائج دقيقة للأعتاب المسلحة.