

ROTATION OF LOCAL COORDINATE FOR ANALYSIS DRAWING PPROCESS OF METAL POLYGONAL SECTION BY (FEM)

Saad Theyyab Faris¹ , and Jabbar Kasim Jabbar²
^{1,2}College of Engineering , Diyala University

(Received:16/4/2008 ; Accepted:15/9/2008)

ABSTRACT -The most important activity of metal forming technology is the correct design of stages geometry for economic consideration in order to increase the metals utilization coefficient and the productivity realized products with high dimensional accuracy and a finer quality of worked surface. In this Study the rotation of local coordinate by using finite element method through (M. S. C / Nastran) are investigating with influencing of some parameters such as , Reduction area , Simi die angle and friction factor to obtain the stresses and strains developed during the drawing process of polygonal section from round section .The results show that its possible to use the technique of rotation of local Coordinate in all programs of (F.E.M) to analysis metal forming process especially when the friction factor = 0.1 , Simi die angle = 9° , Reduction area =35% which are gives good agreement to the results of (U.B.T)and the practical results.

1. INTRODUCTION

Attention is being increasingly paid to the drawing of section rod from round stock as this operation offers the promise of an economic production route the process is attractive also, because draw machines are readily available and the necessity to purchase expensive section stock corresponding to multiplicity of required section was eliminated , However the direct cold drawing of section rod from round bar through a single die has not been practiced widely because of the difficulties experienced in establishing the optimum die profile to form an accurate section and in allocating the work to draw machines, Equally , theoretical consideration of this operation has been neglected a simple analytical techniques can not yield valid relationships consequently ,Some consideration is now given to the mechanics of

direct drawing of symmetrical sections to enable the draw force calculated from known characteristic of the work piece and die .

In previous works, a paper describes a new method for obtaining optimal die shape which produces minimal stress in the drawing of non ax symmetric section from round bar stock .An Upper Bound Theory based on kinematically admissible velocity field used to determined the forming stress for different regular polygonal section for a given reduction of area, mater property and frictional condition⁽¹⁾. Another paper obtained the max reduction of area from lower bound analysis in direct drawing, the equivalent die angle can be optimized for every relevant combining of friction and reduction of area⁽²⁾. Analysis of drawing polygonal section throw streamline die by the method is applicable to other curved dies such parabolic convex or concave shape. The concluded that the streamlined die is superior to the straightly converging dies from a aspect of reducing the load⁽³⁾.

An Upper Bound analytical method are found in order to investigate the drawing process of rod non symmetric cross section using simulation technique. the drawn force is calculated in terms of (cross section) of product, die length, reduction of area friction and material properties⁽⁴⁾.A research concerning deep drawing simulation to improve the robustness and accuracy to decrease the computation time of real life Finite Element Method, A mixed elastic-plastic / rigid plastic material model which is takes advantage in accuracy and fast convergence over a large of plastic strain increments⁽⁵⁾.

By used a numerical procedure to design die of deep drawing process throw (F.E.M) to study the effect of some parameters which influence the drawing process such as friction factor, blank holding force, punch and die corner radius. The results showed that the best initial blank holding force equal 10 KN with out failed, minimum die corner radius equal 4 mm, Increasing the value of friction coefficient from (0.1) leading to increasing the cup height⁽⁶⁾. The producers of wire enter processes of cold workability which are found at the boundary of the while long known ones. The working of round wires in round oval round succession among two couples of roller situated in a contrary plan with wire passing between them under action of a drawing force is placed to the boundary between drawing and rolling both from tensile state point of view or from workability point of view⁽⁷⁾. Using stainless threads have application requiring softness and flexibility abrasion resistance this made by drawing in fully annealed stock to final diameter with out any intermediate heat treatment the method by which specimens were prepared from this fine wire .show the true strain amounts to about 6.3 . this is interesting from metallurgical point of view because theory indicates that whereas the defects created by deformation increase the number density of nucleation sites and hence

promote nucleation, the movement of the marten site austenite interface is obstructed by the defects when the strain become sufficiently large it become impossible for the interface to move causing the translation to half⁽⁸⁾.

This study presents a good technique by finite element method through (M.S.C / Nastran) by rotation of local coordinate of the shape draw polygonal section from around billets through a converging die were the die surface defined by an envelope of straight streamlines As an integral part of this analysis it is shown that dimitation on the draw force and the deformation restrict both the maximum and minimum reduction of area obtainable based on energy consideration the main draw force , mean die pressure and mean equivalent strain are calculated in some detail with the aid of a computer programmed taking the drawing of square section from round rod as an example also its shown that there is a good agreement between published theoretical and experimental data for the drawing of round from round bar , with the corresponding theoretical results calculated from this new analysis for the drawing of ax symmetric section having an infinite number of sides .

Using this method geometry which requires the minimal forming stress can be determined for polygonal section with respect to reduction of area, die geometry, material properties and frictional conditions, a brief review relevant to the subject discussed here follows in the next section.

DIE CONFIGURATION

By using round billets from pure aluminum material in cold drawing (AL 1060 – O) as material deforms to the final polygonal section rod through the stainless steel die defined by an envelope of a number of straight lines on the die surface.

However the examination of the three dimensional material flow inside the die is difficult and this has not been investigated in this research nevertheless when design aide, a smooth flow of material is an important factor which many reduce the total power consumption due to the plastic deformation and produce a defect free product. The die design should be undertaken in such a manner so as to avoid the needles bending and twisting of particles as much as possible.

The subsequent complex die geometry can be manufactured easily, thanks to the advances in CAD/ CAM technology.

VELOCITY FIELD

In order to construct the kinematically admissible velocity field the following assumption are made:

1. The reduction ratio is kept constant with the subdivision of the material in to small elements.
2. The plastically deforming zone is bounded by entry and exit shear surface in to small elements.
3. The material is incompressible.

Detailed mathematical formula to obtain the velocity components are described in reference [1] and only the major differences between the present and previous methods are presented in this study. By using (Upper Bound Solution). The total power consumption inside the die is the sum of the power losses due to the plastic deformation (WI) the velocity discontinuities at inlet (WE) and outlet (WF) of the die and the friction along the interface between the material and the die (WS) .The predicted total power obtained through the present velocity field would be higher than the power actually consumed.

Each power was computed numerically using velocity components , subsequent strain rate components and the yield stress for different frictional conditions , the volume and surface integrations are carried out numerically using Simpson's rule , once the total power consumption (J*) is obtained , the Upper limit to the average pressure (Pave) for drawing is given by:

$$Pave = \frac{J^*}{N a^2 \tan(\omega m) V f} \quad \text{----- (1)}$$

$$WI = \frac{2 \dagger_o}{\sqrt{3}} \iiint_v \left(\frac{1}{2} v_y x v_y \right)^{\frac{1}{2}} dv \quad \text{----- (2)}$$

$$WE = \frac{\dagger_o}{\sqrt{3}} \iint_{s_1} |\Delta v_o| ds_1 \quad \text{----- (3)}$$

$$WF = \frac{\dagger_o}{\sqrt{3}} \iint_{s_2} |\Delta v_F| ds_2 \quad \text{----- (4)}$$

$$WS = \frac{-m \dagger_o}{\sqrt{3}} \iint_s |\Delta v| ds \quad \text{----- (5)}$$

$$J^* = N [WI + WE + WF + WS] \quad \text{----- (6)}$$

$$WT = 2J^*$$

$$WT = 2 N (WI + WE + WF + WS) \quad \text{----- (7)}$$

$$R_s = \frac{P_{ave}}{\dagger_o} \quad \text{----- (8)}$$

$$\dagger_R = \frac{\dagger_D}{\dagger_o} \quad \text{----- (9)}$$

$$\text{Power} = \dagger_D Vf Af \quad \text{----- (10)}$$

$$Vf Af = Vo Ao \quad \text{----- (11)}$$

$$WR = WE + WF \quad \text{----- (12)}$$

$$\dagger_R = \left(\frac{WT}{\dagger_o V_o L^2} \right) x \left(\frac{2(L/R_o)}{\Pi} \right)^2 \quad \text{----- (13)}$$

ROTATION OF LOCAL COORDINATE

The previous method in drawing or extrusion using (contact element) and interface element to find the effect of reduction area ration for various profiled direct forming dies contour under the condition of ax symmetric and frictionless condition.

In this study drawing process was analyzed by using (FEM) to find the influence of some parameter such as reduction area, semi die angle, friction factor and geometry of die on the relative drawing stress throw new technique defined as rotation of local coordinate which gave result closed to the practical result of (U.B.T) because all nodes of rod in contact with the die were rotated an angle equal to the die semi – angle as show in Fig. (2).

The chemical composition of aluminum (AL 1060 – O) used wt%

% Al	% Fe	% Si	% Cu	% Zn	% Mg	% Mn
Rem.	0.11	0.135	0.001	0.05	0.0045	0.0015

RESULTS AND DISCUSSION

Using above mentioned analytical method based on the (F E M) theory numerical calculation have been successfully performed concerning the effect of cross sectional profile , reduction of area , die length and friction factor on the drawing force .

1. Effect of Cross Section Profile

Figure (3) shows effect of the cross section profile of die on drawing process through the relationship between relative stress & number of sides of product (N). In the drawing through the streamlined die the relative stress decreases exponentially with the increase of number of sides whereas the power consumed due to die surface friction equal 0.05 & R=35%, When the sides = 14 show the result is the same in circle profile & lower than square because of high friction which cause un streamlined flow, therefore increase the power deformation as show in Figure (8) .

2. Reduction of Area of Pass

Maximum allowable reduction of area per pass an upper limit to reduction of area achievable is imposed in cold drawing process by tensile failure of the drawn product. That is rupture occurs when the stress in the drawn wire equals or exceed the maximum tensile stress of the drawn material, fig (8) (9) represent the compare in reduction of area which show the increase of major strain distribution. In practice when wire is drawn with a reduction of area close to the limiting reduction, the drawn stress is very nearly equal to the maximum tensile stress. The maximum value of the reduction of area is calculated by a method out lined in this study for the drawing of round bar to square (rod symmetrical) section and the results are plotted in figure (4) (5) .

3. Effect of the Friction Factor and the Die Length

Fig (4) Shows effect of the friction factor (A_m) on the relationship between relative stress & reduction of area. In the drawing through the streamlined die. The magnitude of the power consumed due to plastic deformation is quite appreciable as apart of the total power consumption. This power decreases exponentially with the increase of die length whereas the power consumed due to die surface friction gradually increases as in fig. (2), the increase rate of which is dependent upon the friction, therefore an effort should be made to reduce the die surface friction in order to reduce total power consumption effectively .the result of the present method according to figure (5) and the result obtained by the researcher in reference [9] which show a good agreement with this study the friction is dependent not only on the die angle but also on the reduction of area.

4. Influence of Increasing the Load & Semi Die Angle

Figures (6,7) shows the influence of increasing the load on the drawing force distribution of strain in the forming zone , when the equivalent die semi angle equal (8 to 10 deg.) show low stress with the reduction of area = 35 % .The spacemen start with forming

when the force drawing equal (650 N) increasing this load up to (1300 N) causes increasing the equivalent strain because of the increase in the amount of the interval shear deformation of the material in the die .In compare with the reference (10) show a good agreement as shown in Figure (11).

CONCLUSIONS

A new analytical method base on the (F.E.M.) has been developed in order to investigate the drawing processes of polygonal section with axis metric cross sections. In this analysis , generalized formulas of the kinematically admissible velocity field of the material in the die are newly presented and mathematical procedure to deformation of the material and to calculate the tool power of deformation are developed .

Using this method. Energy requirements, drawing stress, optimal die length and dimensions of dead zone are calculated successfully. Through these works it becomes clear that the analytical method developed in this study is very flexible and can be applied generally to a non symmetric drawing processes. By this method, it has become possible to make systematic investigation in to those processes or to predict optimum dimensions of the die and working conditions necessary for the required product.

Geometry which requires the minimal forming stress can be determined for polygonal section with respect to reduction of area, die geometry, material properties and frictional conditions.

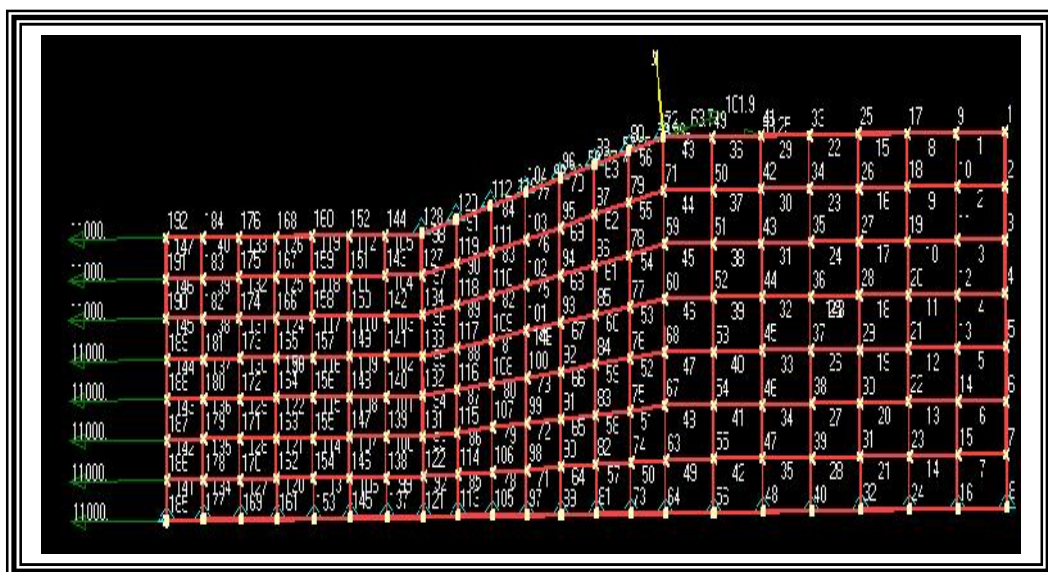

Fig. (1). Model of unreformed Mesh shows Elements and Nodes Numbers

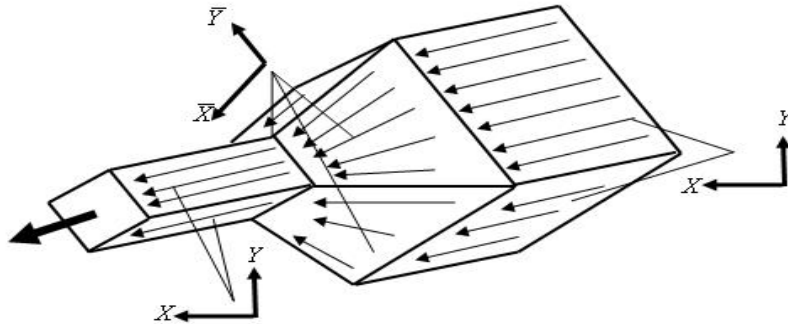

Fig. (2). Show the Rotation of Local Coordinate Method.

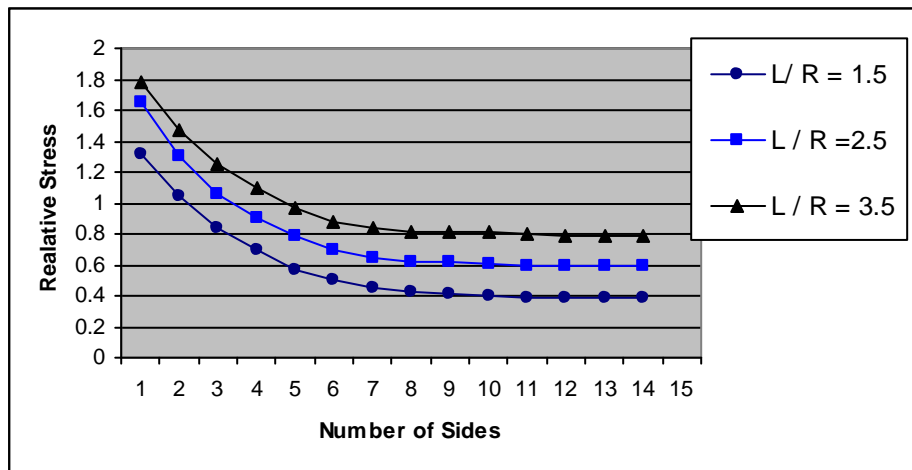

Fig. (3). Effect of Cross Section Profile on the Drawing Process. When Reduction of Area = 35% & $A_m = 0.05$

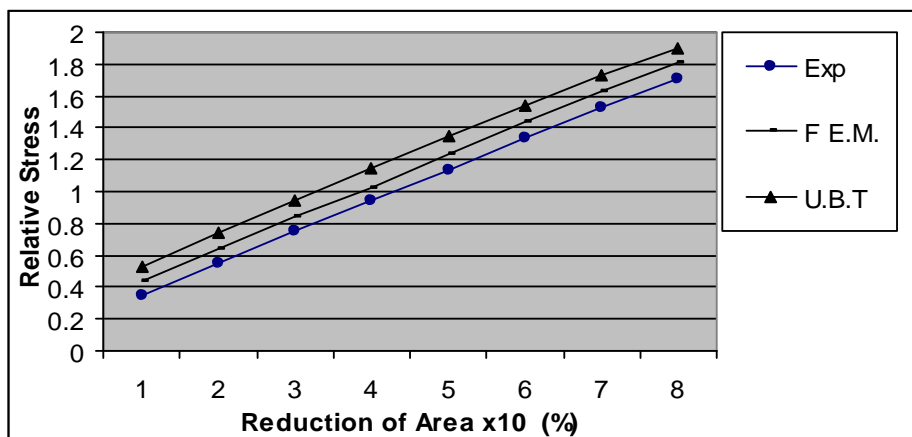

Fig. (4). Relationships between reduction of area & relative Drawing stress (Comparison with U.B.T & Exp results)

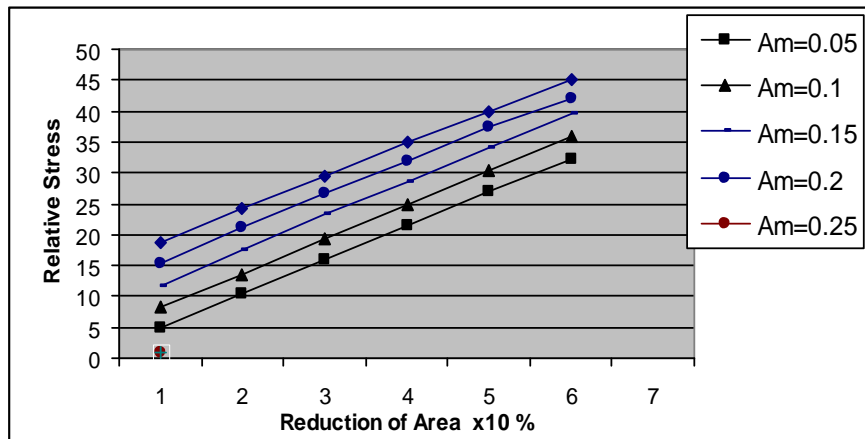

Fig. (5). Effect of friction on the drawing stress with Reduction of Area.

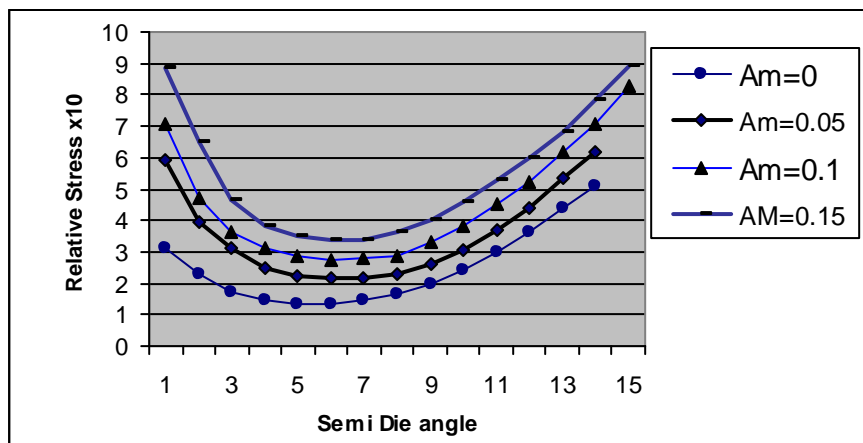

Fig. (6). Relationships between semi die angle & Relative drawing stress in variation of friction factor.



Fig.(7). Relationships between semi die angle & Relative Drawing stress in friction (Am= 0.05) (Comparison with U.B.T & Exp results)

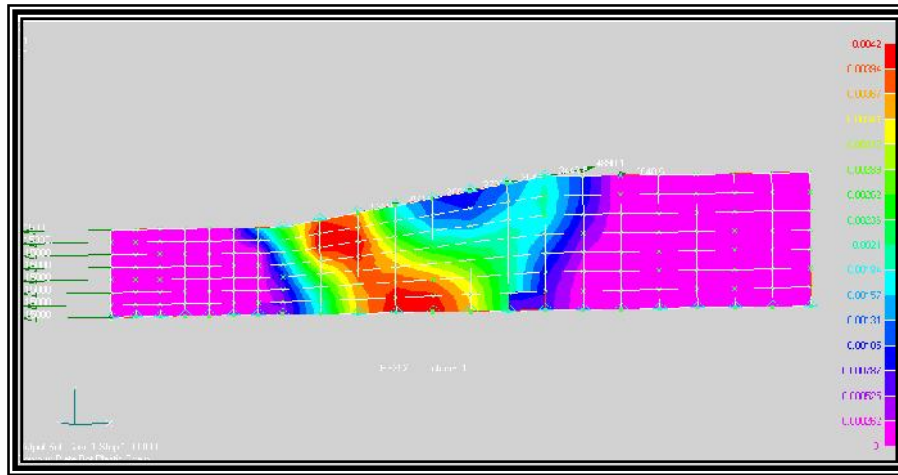

Fig. (8). major strain distribution when R=35% & friction Factor=0.1, semi die angle = 15°

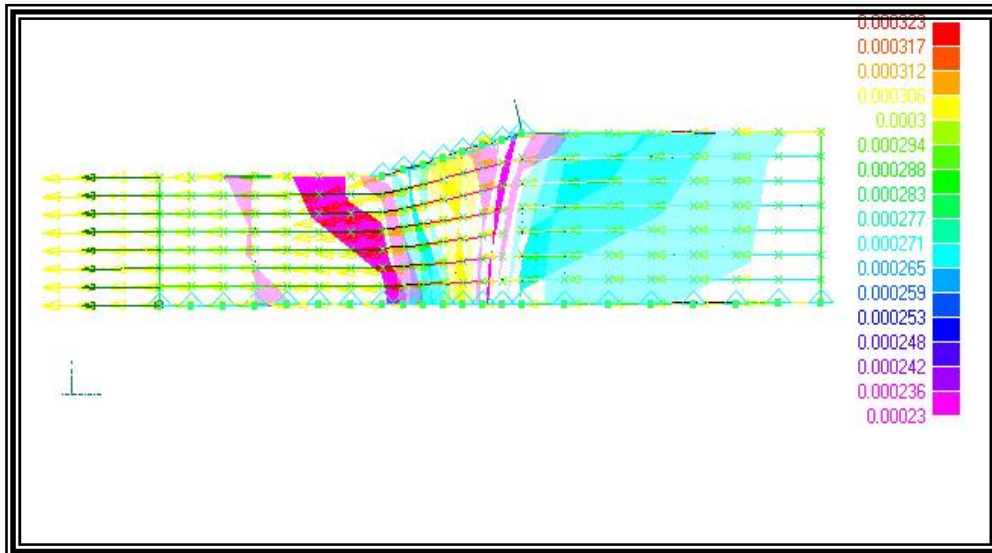

Fig. (9). major strain distribution when R=25%, friction Factor=0.1, semi die angle = 15°.

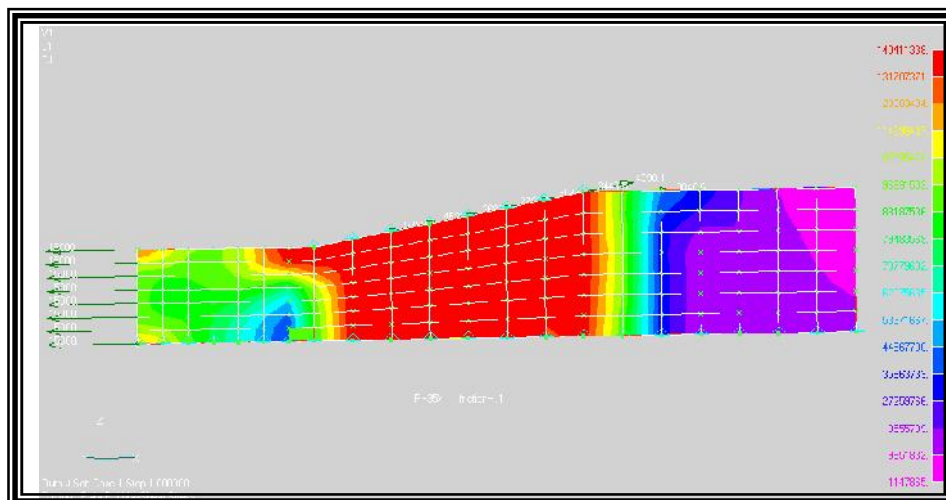

Figure (10). Variation of the drawing Stress distribution

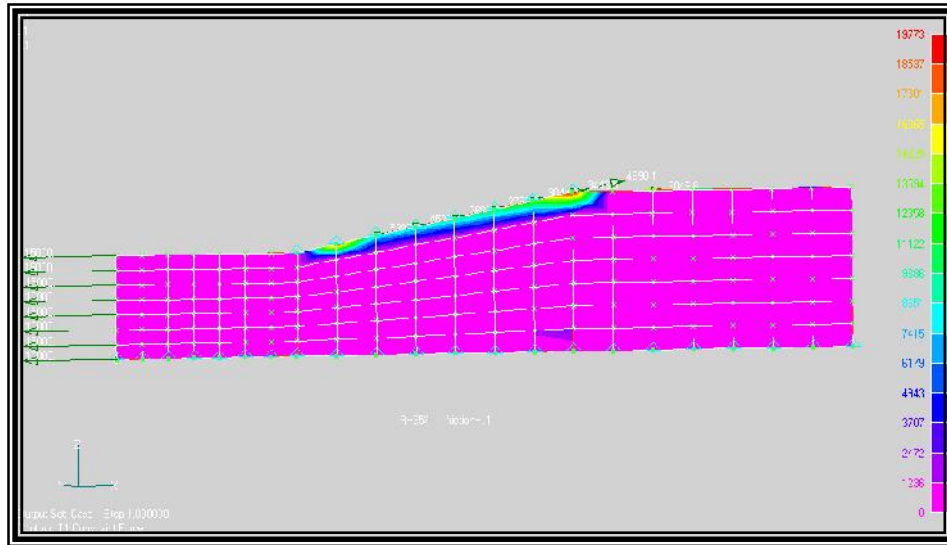

Fig. (11). Distribution Reaction forces contact zone

REFERENCES

1. S. Hoshino "An Upper Bound Solution for the Drawing or Extrusion of Square Section from Round Bar Through Converging Die" Int. J.Mech Tool Design Res. No 21 pp (97 – 107) [1988].
2. B.B.Basily& D.H.Sansome "Some Theoretical Consideration for the Direct Drawing of Section Rod" Int. J Mech Sci Vol 18 pp (201- 208)University of Astone –England Birmingham [1988].
3. J.S.Gunasekera "Analysis of Drawing of Polygonal Section Through Straightly Converging Dies" Jernal.Eng.Lnd Trsaction of the ASME Vol 104 PP (38-45)[1998].
4. M. Kivchi "Study on Non Symmetric Extruction and Drawing"University of Tokyo Japan, Inter. Mech Tool Design Res. Conf.No 3 / 22nd pp (523 – 532) [1998].
5. Timo.Menders"Simulation of Sheet Metal Forming Processes" ph.D Thesis Department of Applied Mechanics Section University of Twente .P .O Canada [1999]
6. W. K. Jawad "Study the Effect of Die Geometry on Deep Drawing Operation Using Finite Element Method" Ph.D Thesis University of Technology Department of Production & Engineering and Metallurgy / Iraq [2003].
7. L. Nistor & M.Tintelecan "Modeling of Geometry Design in Wire Drawing Using Cassette Roller Die "Advanced Materials Research. Vol 23 [2007] pp (173 – 178) .

8. Han .Shen. Wang "Characterization of Severely Deformed Austenite Stainless Steel Wire "National Tawan University, Materials Science and Technology Vol 21 [2005] pp (1323 – 1328) .
9. Talal. Abdul Jabber Abdul Wahab "Cold drawing for ax Symmetric Section bar "PhD Thesis university of Bradford England [1989].
10. A.R. Ismail "Investigation of the Effect of Area Reduction Ratio for Various Profiled Direct Extrusions Dies Using (F.E.M) University of Technology Eng. & Journal No 2 / Vol 21 pp (60 – 73) [2002] .

SYMBOLS DESCRIPTION

Ri	radius of inlet circular section
Ro	radius of outlet
H	die height
N	number of sides
Ao	area ratio
Γ	die semi angle
J*	the actual externally supplied power
Vx,Vy,Vz	Velocity components in the Cartesian Coordinate system
WI	power due to plastic deformation
WE	Power due to velocity discontinuity at the die entry shear plane
WF	Power due to velocity discontinuity at the die exit shear plane
WS	power due to the die surface friction
J	Jacobean of the coordinate transformation equation
L	length of die which is the distance between the entries and the exit shear planes of die
Pave	average pressure on ram
e o	components of strain rate tensor
Qo	yield stress of rigid perfectly plastic material
Am	friction factor

تدوير الإحداثيات الموقعية لتحليل عملية سحب المقاطع المعدنية المضلعة بطريقة العناصر المحددة

جبار قاسم جبار
مدرس مساعد
كلية الهندسة-جامعة ديالى

د.سعد نزياب فارس
مدرس
كلية الهندسة-جامعة ديالى

الخلاصة

الاهمية الاكثر فاعلية لتكنولوجيا عمليات تشكيل المعادن هي التصميم الصحيح للمراحل الهندسية لبعض الاعتبارات الاقتصادية من اجل زيادة التماثل للمتغيرات وزيادة الانتاجية بابعاد عالية الدقة والنوعية للسطح المشغل لذا في هذه الدراسة تم استخدام طريقة العناصر المحددة من خلال التوصل الى طريقة تدوير الاحداثيات الموقعية للمعدن المشكل الذي يتماس مع سطح قالب سحب المقاطع المضلعة وتحليل عملية السحب بوجود بعض المتغيرات المهمة مثل التخصر بالمساحة ، زاوية نصف القالب، عامل الاحتكاك و مدى ظهور تأثير الاجهادات والانفعالات خلال عملية السحب النتائج التي تم الحصول عليها بينت ملائمة استخدام هذه التقنية مع طريقة العناصر المحددة بصورة جيدة لعملية التشكيل خصوصا عندما كان معامل الاحتكاك = 0.1 وزاوية نصف القالب = 9° ونسبة التخصر بالمساحة = 35% وهذه اعطت توافق بشكل جيد مع نتائج نظرية الحد الاعلى والنتائج العملية