

INVESTIGATION OF SOME PARAMETERS INFLUENCING OF THREE DIMENSIONAL TUBE EXTRUSION PROCESS OF ELLIPSE SECTION THROUGH STREAMLINE DIE

Saad Theyyab Faris¹, and Eklas Edan Kader²

^(1,2) Engineering College , Diyala University
(Received:18-4-2009 ; Accepted:5-9-2009)

ABSTRACT - In cold lubricated tube extrusion of ellipse section the material properties and surface quality of the extruded products are influenced by the die profile so in the present analysis the axial velocity component on the intermediate cross-section in the plastically deforming region is expressed as a general function of the coordinates . This allows the description of complete three dimensional distortion of flow rendering more realistic flow patterns .From the derived kinematically admissible velocity field , corresponding upper-bound theory the extrusion pressure is then obtained by optimizing the pressure with respect to the given parameters ..The effective strains are computed in order to study the work hardening pattern of the extruded products ,also (F.E M) by ANSYS (11) software was used in building, loading and solving the extrusion process, the model generation depends on the Billet (AL 2024 fully annealed) have been carried as the working material. In the computation the product shape was ellipse with the effects of area reduction, die length product shape complexity and frictional condition on the extrusion pressure, the metal flow and distribution of the final effective strain have been studied extensively. The simulation using (ANSYS 11 PROGRAM), theoretical predictions both in extrusion load and metal flow are in good agreement with the experimental results.

KEY WORDS:- tube extrusion, ellipse section, streamline die.

SYMBOLS DESCRIPTION

Ri radius of inlet circular section (mm)

Ro radius of outlet (mm)

H	die height (mm)
Ao	area ratio
Γ	die semi angle
J^*	the actual externally supplied power
V_x, V_y, V_z	Velocity components in the Cartesian Coordinate system
WI	power due to plastic deformation
WE	Power due to velocity discontinuity at the die entry shear plane
WF	Power due to velocity discontinuity at the die exit shear plane
WS	power due to the die surface friction
J	Jacobean of the coordinate transformation equation
L	length of die which is the distance between the entries and the exit shear planes of die
Pave	average pressure on ram
Am	friction factor
V_m	mean velocity on the cross section

1- INTRODUCTION

Cold extrusion of sections through continuous dies or so called streamlined dies has many advantages such as good surface finish. Prevention of defects and improved material properties in axisymmetric tube extrusion problems. Various solutions have been proposed by researchers such as Avitzur⁽¹⁾ and Williams⁽²⁾. As for three-dimensional tube extrusion problems there have been only a few analytical studies in the last decade Yang and Lee⁽³⁾. Investigation into lubricated extrusion of round tubes through streamlined dies considering the plastic flow de. Prakash and Juneja⁽⁴⁾ found an upper bound solution for tube extrusion of polygonal sections by utilizing the conventional spherical velocity field. Their solution is limited to polygonal sections whose sides must be inscribed by a circle. Kiuchi^(5,6) found an upper bound solution for tube extrusion through arbitrarily shaped dies under the assumption that the axial velocity is uniform at any cross section. In the analysis the analytical representation of a curved die surface was not considered. Thus far no analytical method has been reported in which the three-dimensional plastic flow can be predicted for generalized tube extrusion of arbitrarily shaped sections. The objective of this study is to develop a generalized analytical method for three dimensional tube extrusions of various sections through continuous dies considering the realistic plastic flow. A general kinematically

admissible velocity field is derived to formulate an upper bound solution. The corresponding upper bound solution is then obtained by minimizing the extrusion power with respect to some given parameters. The effects of area reduction frictional condition and tubular shape ratio etc. are discussed with regard to extrusion power. Distribution of the final effective strain on the cross section of the extruded billet. In this research ANSYS (11) software was used in building, loading and solving the extrusion process. By constraining the die by exerting a displacement equal to zero to all die surfaces and making the time stepping control off, loading the model with constant pressure and giving the product a displacement in the axial direction according to the extrusion velocity (5 mm/min) in many time step loading and recording the effect of loading and the Billet movement on the die rigidity and validity ,and the Billet shape and behavior according to extrusion process.

2- ANALYTICAL ANALYSIS

Upper bound formulation

In order to construct the kinematically admissible velocity field the assumption made are:

1. The working material is assumed to be rigid and perfectly plastic which follows a Particular strain hardening curve, incompressible and follow Von Misses yield condition. The die is assumed to be rigid.
2. The deformation zone is bounded by straight plastic boundaries at the entry and at section Of the die, the plastic zone is assumed to be bounded by two planes which are Perpendicular to the z-axis at the entrance and exit of the die.
3. The elastic strain is small.
4. Friction factor between the die and work piece material is assumed to be independent of slip.
5. Deformation takes under place homogenous and steady state conditions. fig.(1) shows a schematic of tube extrusion through an arbitrary shaped die.

In the present analysis the die shape can be expressed in cylindrical coordinate system, the inner die profile is given by an analytical function $R(Oz)$ by which an arbitrary mandrel shape can be represented, the inner die profile was simplified by using a mandrel of constant diameter attached to the punch for the three dimensional flow the incompressibility condition is given by ^(7,8):

$$\frac{1}{r} \frac{\partial}{\partial r} (rV_r) + \frac{\partial V_z}{\partial z} + \frac{1}{r} \frac{\partial V_\theta}{\partial \theta} = 0 \quad \dots(1)$$

For the sake of convenience in analysis the axial velocity component V_z can be divided into two terms.

$$V_z(r, \theta, z) = V_m(z) + F(r, \theta, z) \quad \dots(2)$$

The first term denotes the mean velocity on the cross section at z and is defined by

$$V_m(z) = V_o S(o) / S(z) \quad \dots(3)$$

Where $S(z)$ is the cross sectional area at z . The second term is the velocity deviation from the mean velocity at a local point (r, θ, z) on the given cross section. The axial velocity component expressed by equation (2) must satisfy the incompressibility equation (1) therefore, the function $F(r, \theta, z)$ must satisfy the following constraint.

$$\int_{s=z} F(r, \theta, z) ds = 0 \quad \dots(4)$$

Fig.(2) shows the effect of die shape on velocity field. The schematic of three dimensional extrusion of elliptic section from around tube through a continuous die is shown in fig. (3) Any intermediate section can be defined such as an elliptic cross section as follows in Cartesian coordinates

$$\frac{x^2}{f^2} + \frac{y^2}{g^2} = 1 \quad \dots(5)$$

In order to obtain an explicit form for the die profile equation (5) can be transformed into a cylindrical coordinate system as follows.⁽⁷⁾

$$v_{r,\theta}(r, \theta, z) = \frac{1}{2} \left(\frac{\partial V_r}{r \partial \theta} + \frac{\partial V_\theta}{\partial r} - \frac{V_\theta}{r} \right) \quad \dots(6)$$

$$R_o(\theta, z) = fg [g^2 \cos^2 \theta + f^2 \sin^2 \theta]^{-1/2} \quad \dots(7)$$

$$v_{r,z}(r, \theta, z) = \frac{1}{2} \left(\frac{1}{r} \frac{\partial V_\theta}{\partial z} + \frac{\partial V_r}{r \partial \theta} \right) \quad \dots(8)$$

$$v_{r,z}(r, \theta, z) = \frac{1}{2} \left(\frac{\partial V_r}{\partial z} + \frac{\partial V_z}{\partial r} \right) \quad \dots(9)$$

$$J^* = W_i + W_f + W_s \quad \dots(10)$$

$$W_i = \int_V \tau v dV \quad \dots(11)$$

$$W_i = \frac{2}{\sqrt{3}} \tau_m \int_0^L \int_0^{2f} \int_{R_i}^{R_o} \left(\frac{1}{2} v_{ij} v_{ij} \right)^{1/2} r dr d\theta dz \quad \dots(12)$$

$$Wf = \frac{m}{\sqrt{3}} \dagger_m \int_0^{2f} \int_0^L (V_r^2 + V_r'^2 + V_z^2)^{1/2} x \left[1 + \frac{1}{Ro^2(n,z)} \left\{ \frac{Ro(n,z)}{\partial z} \right\}^2 + \left\{ \frac{Ro(n,z)}{\partial z} \right\}^2 \right]^{1/2} Rod_n dz$$

$$+ \frac{m}{\sqrt{3}} \dagger_m \int_0^{2f} \int_0^L Vz Ri d_n dz \quad \dots(13)$$

$$P_{avg} = \frac{J^*}{f (1 - Ri^2 / Ro^2(n, O)) Vo} \quad \dots(14)$$

3- EXPERIMENTAL SOLUTION

The experimental set-up was manufactured for tube extrusion of sections from round billets and was installed in a 400 ton hydraulic press. Using an Nc machined, As working material fully annealed Al 2024 was chosen, and the billets were machined to have the dimensions of 29.5 mm in diameter and 80 mm in length the outer diameter was changed according to reduction of area which were changing from 30% to 80%. The stress –strain curve was obtained through curve fitting from a compression test as follows.

$$\dagger = 441 .5(v)^{0.275} \text{ (MPS) .}$$

This equation was solved to obtain the stress –strain values to all the loading pressure to extrude the product with specified final diameter.

The deformation patterns were visualized by using the grid marking technique. Square grids (1mmx1mm) were applied on to the meridional plane of each half-cut billet .Two half-cut billets were put together and extruded with the split surface set in a specific direction .

The specimens were lubricated with a mixture of (MoS2) powder and grease. Friction factor was found to be (0.12) from a ring compression test. The extrusion load was measured by a strain gage load cell of 150 ton capacity. Attention was paid to the values of the extruded length and the measured load so that they could reach a sufficient value to establish the steady state of the process.

4- COMPUTATIONAL ANALYSIS

1. Model Generation

The ultimate purpose of a finite element analysis is to recreate mathematically the behavior of an actual engineering system. In other words, the analysis must use an accurate mathematical model of a physical prototype. In the broadest sense, this model comprises all the nodes, elements, material properties, real constants, boundary conditions, and other features that are used to represent the physical system. In this research ANSYS (11) software

was used building, loading and solving the extrusion process.

In ANSYS terminology, the term model generation usually takes on the narrower meaning of generating the nodes and elements that represent the special volume and connectivity of the actual system. Thus, model generation in this discussion means the process of defining the geometric configuration of the model's nodes and elements. The model generation depends on the Billet (AL 2024 fully annealed) initial diameter which is constant and equal to 29.5 mm and the final diameter which change according to the reduction of area to be obtained from 30% to 80 % . In this research the reduction of area will be 30%, 50% and 80% this means that the final diameter will be equal to 25 mm, 21.2 mm and 13 mm. The element type chooses for the Billet material was solid 20 node 95, shell 8 node for the die and 3D 170 contact for the interfaces surfaces (that will be in contact when the billet extruded through the die) as shown in fig.(4,5a and b) number of elements depends on the division chosen when lines and area meshed using sweep command.

2. Finite Element Solution

The solution was done by loading the model in two steps:

1. constraining the die by exerting a displacement equal to zero to all die surfaces and making the time stepping control off.
2. Loading the model with constant pressure changed from 300 to 1200 MPa in a separate loading, and exert a sliding distance to Billet surfaces in the x-direction in each time step which depends on the velocity of exerting the extrusion pressure (5 mm per minute) in each time step the pressure is constant and the same areas loaded with x-axis displacement to analogue with the Billet moving when it is compressed by exerting a compression pressure. When the Billet material flow from the other end of the model which was hollow with a 3mm diameter hole, the extrusion process is done. Average von mises stress, strain and contact pressure was recorded (although stress, strain and contact pressure can be obtained with different axis). Results estimating extrusion pressure with average stress.

5- RESULTS AND DISCUSSION

The velocity field used in this analysis satisfies all boundary conditions, the incompressibility condition is satisfied throughout the plastically deforming region including the entry and exit plane of the die and the die surface .The upper bound extrusion pressure is calculated as the relative stress which is the ratio between the average extrusion pressure

(Pave) and the flow stress of the material (σ). The relative stresses computed numerically for the ellipse section as a function of die length. The optimal die length which produces the minimum extrusion pressure is obtained for different reduction of area and different frictional condition (m_f) along the interface between the die surface and the material. The relative stress increases with increases in the reduction of area, also the optimal die length shifts towards a smaller value with increase of the frictional factor. The effect of die length on the extrusion pressure and friction factor is shown in figure (6). The results clearly show that for lower value of friction coefficient the stress is expected to be more uniformly for the value of ($m_f=0$) than ($m_f=0.15$) in which the stress value is much more than reasonable values. The simulation result provides large stress equivalent in region of loading because it has bending resistance increase work hardening and higher value of friction. Figure (7) shows the effect of reduction of area on the extrusion pressure with different radius.

Figure (8) shows the effect of friction on the extrusion pressure and average effective strain with different radius Figure (9) shows the effect of reduction of area on extrusion stress for the given die length in three methods, the comparison shows a very good agreement specially after curve fitting of the results, Figure (10) Half section shows the variation of extrusion stress distribution when the reduction of area =80% and ($d=13$) ($m_f=0.2$) Figure (11) Shows the variation of extrusion stress distribution when the reduction of area =80% and ($d=13$) ($m_f=0.3$). Figure (12) shows the variation of extrusion stress distribution when the reduction of area =50% and ($d=21.2$) ($m_f=0.1$). The extrusion pressure increases sharply with increasing reduction of area, this are in good agreement with the reference [9,10] results and with ANSYS (11) results which show that pressure increased from 300 MPa when the reduction of area is 30% to 550 when the reduction of area is 50%, depending on pressure the von misses stress changes from $\sigma_{max} 0.214 E13$ MPa and $\sigma_{min} 1815$ MPa when the extrusion pressure was 900 MPa to $\sigma_{max} 0.4 E13$ Mpa and $\sigma_{min} 2199$ MPa when the pressure was 550 MPa and minimum total strain was $0.242e-09$ and maximum 69.058 as shown in Fig.(13).

Figure (14) Half section elastic strain distribution when the reduction of area = 80% also shows the effect of the die length on the average extrusion pressure, the final average effective strain increase with increasing die length, the non uniformity of deformation increases to some extent with increasing friction factor.

Figure (15) Half section elastic strain distribution when the reduction of area = 67 % these results shows that this is the best reduction of area, simulation using (ANSYS 11 PROGRAM), theoretical predictions both in extrusion load and metal flow are in good agreement with the experimental results. shape complexity factor and friction condition =0.1.

6- CONCLUSIONS

A new analytical method based on the (F.E.M.) has been developed in order to investigate the extrusion process of ellipse section through streamline die with axis metric cross sections.

1. Generalized formulas of the kinematically admissible velocity field of the material in the Die are newly presented and mathematical procedure to deformation of the material and to calculate the tool power of deformation are developed.
2. Using this method Energy requirement, extrusion stresses, optimal die length and dimensions of dead zone are calculated successfully.
3. Through these works it becomes clear that An upper bound formulation has been developed to analyses the metal flow for three-dimensional tube extrusion of arbitrarily shaped section in which the die surface can be expressed by analytical function.
4. Theoretical prediction both of extrusion pressure and of metal flow are in a good agreement with the experiment results.
5. In this study is very flexible and can be applied generally to a non symmetric extrusion processes, it has become possible to make systematic investigation in to those processes or to predict optimum dimensions of the die and working conditions necessary for the required product.
6. Geometry which requires the minimal forming stress can be determined for ellipse section with respect to reduction of area, die geometry, material properties and friction.

7- REFERENCES

1. B. Avitzur , Hand book of metal forming processes , Wiley -Interscience. New York (1983).
2. I.F.Collins and B.K.Williams "Slip line fields for axisymmetric tube drawing " *Int.J.Mech.Sci* 27,225 (1985).
3. D.Y.Yang and C.M. Lee " Investigation into lubricated extrusion of round tubes through streamlined dies considering the plastic flow" . *Ann CIRP* 36 (1997).
4. R.Parkashi and B.L.Juneia " An upper bound analysis of steady state piercing extrusion of polygonal tubes . *J. Engng proc* 1 , 47 (1987).
5. M.Kiuchi" Overall analysis of non- axisymmetric extrusion and drawing" *Proc.12th NAMRC* 111(1998).

6. D.Y.Yang and C.M. Lee "Analysis of Three –Dimensional Extrusion of Arbitrarily Shaped Tubes "Int.J .Mech. Sci / vol / 32 No 2 pp 115 (1996).
7. John Bird "Higher Engineering Mathematics "fifth edition pp705 -737 (2006) published by Elsevier Ltd , Great Britain.
8. T.Z.Blazynski "plasticity and modern metal forming technology" Elsevier Applied Science , London and new York (1989) pp(208-240).
9. JAMES STEART (Calculus) Vector Function And Space Curve) McMaster University United States \Second eduction ((PP705-737)) 2001.
10. Azal R. I." Numerical of 3D Regular polygonal Sections in Forward Extrusion by Elastic – Plastic Finite Element Method " PhD Thesis , Dep. of Production Engineering and Metallurgy University of Technology (2002).
11. S.kumar "A finite Element Thermal Model for Ax symmetric Cold and Hot Extrusion Using Upper Bound Technique" IE(I) Journal - Mc Vol 85 July 2004.

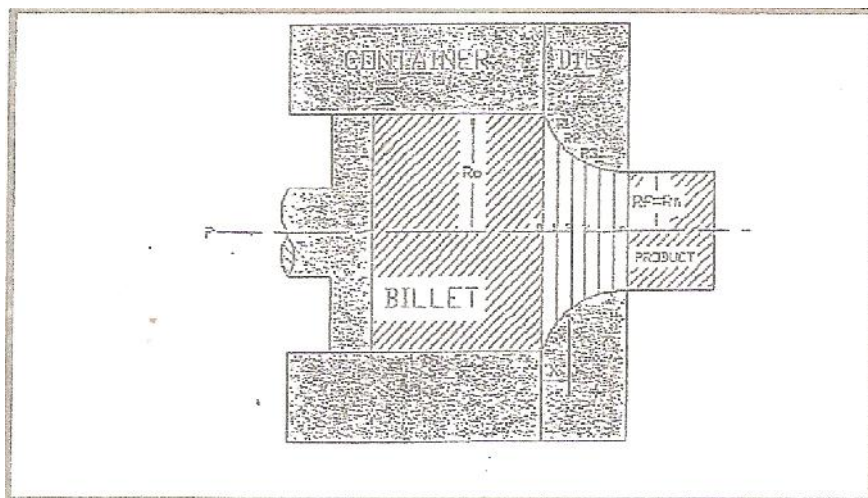

Fig. (1):- Schematic of tube extrusion through an arbitrary shaped die

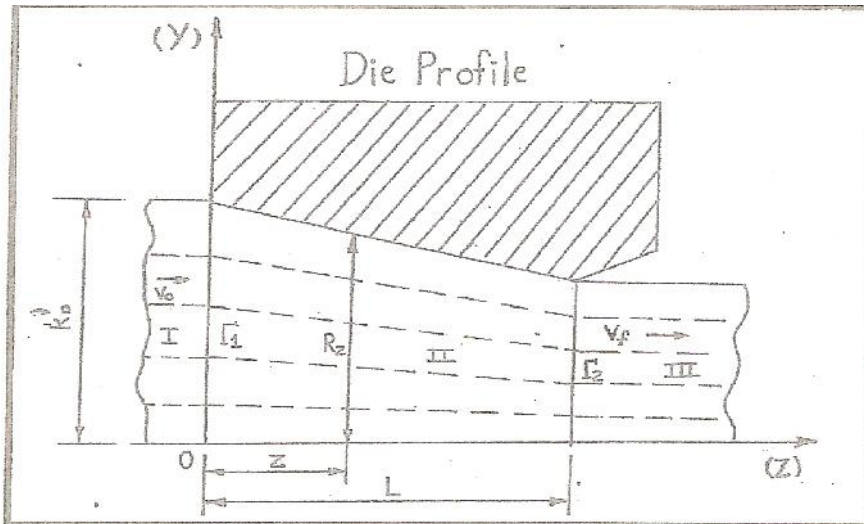

Fig. (2):- The effect of die shape on velocity field

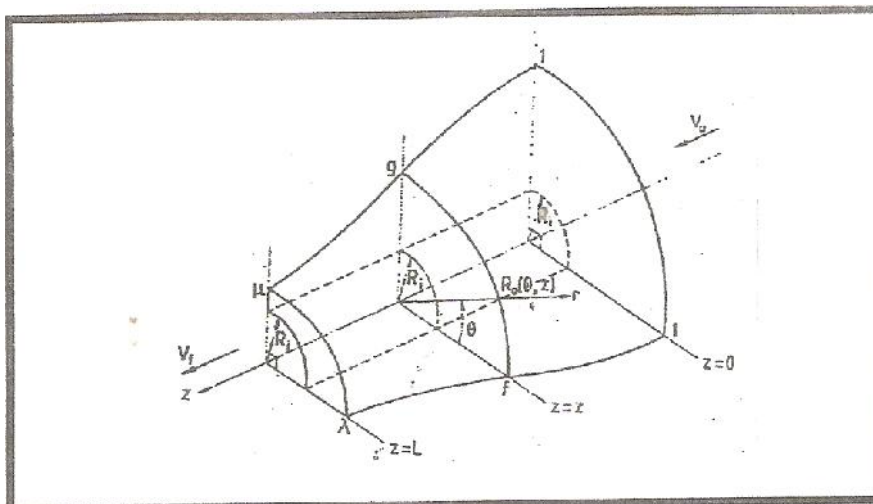

Fig. (3):- The schematic of three dimensional tube extrusion of an elliptic section from around tube

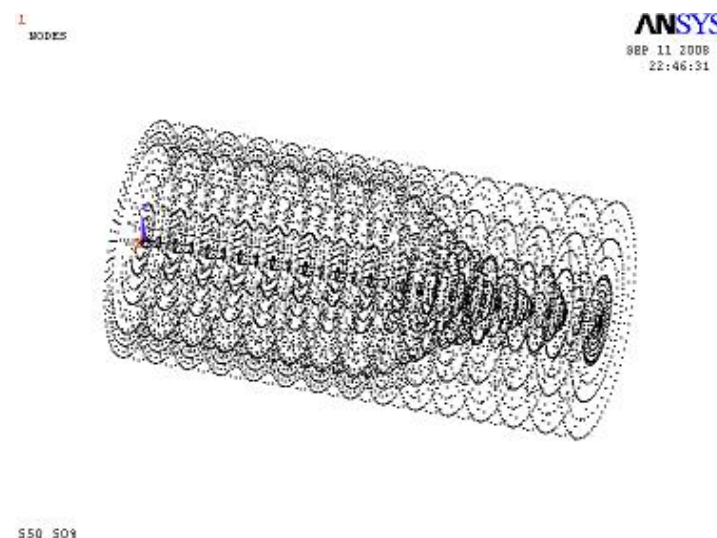

Fig.(4):- Node arrangement of die and Aluminum billet

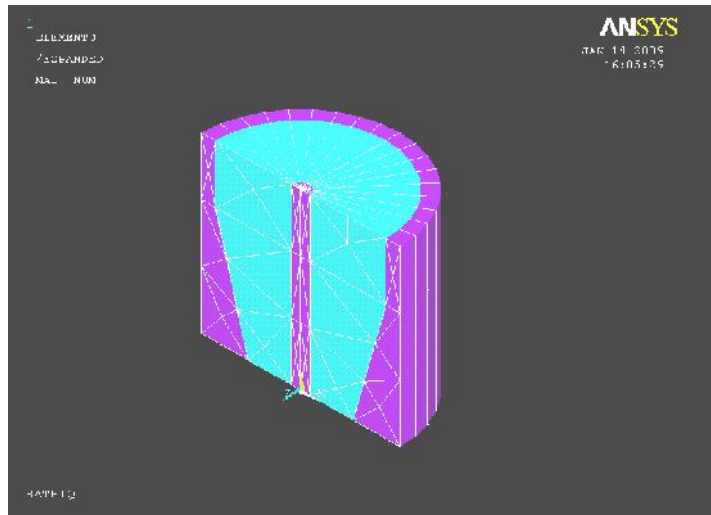

Fig. (5):- a- Mesh of die and aluminum billet (Vertical Section Solid 20 node 95, Shell 8 nodes for the die)

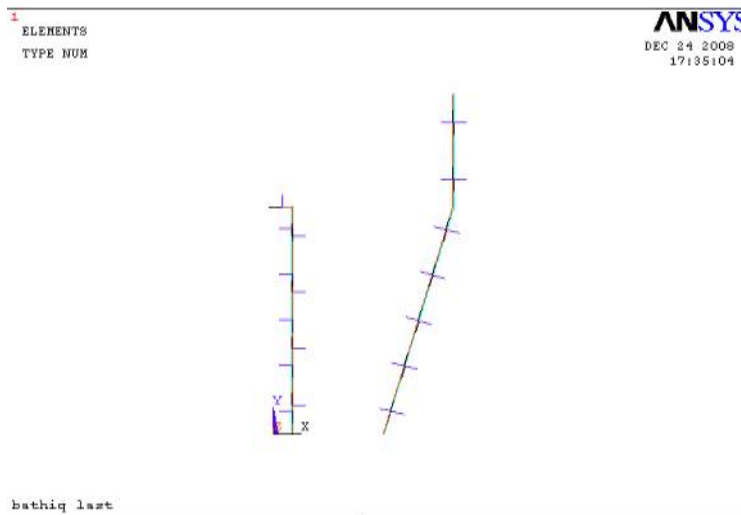

Fig. (5):-b-contact between aluminum billet and die

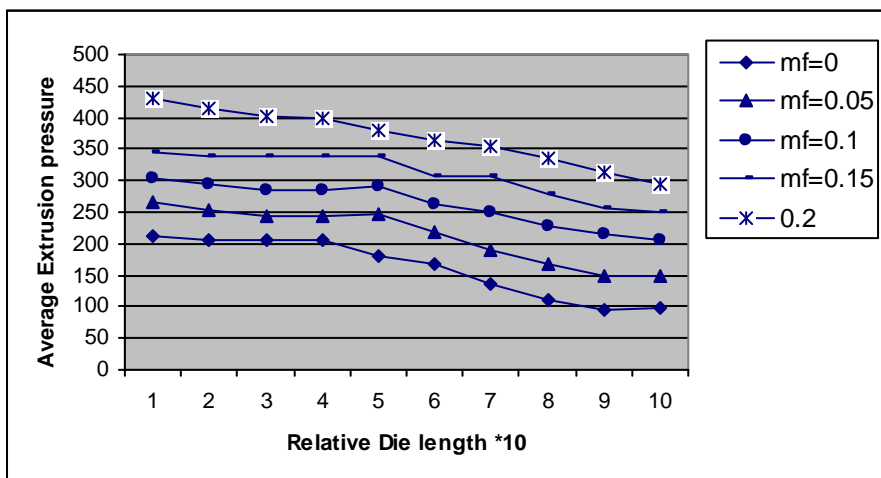

Fig. (6):- Effect of die length on the extrusion pressure and friction factor

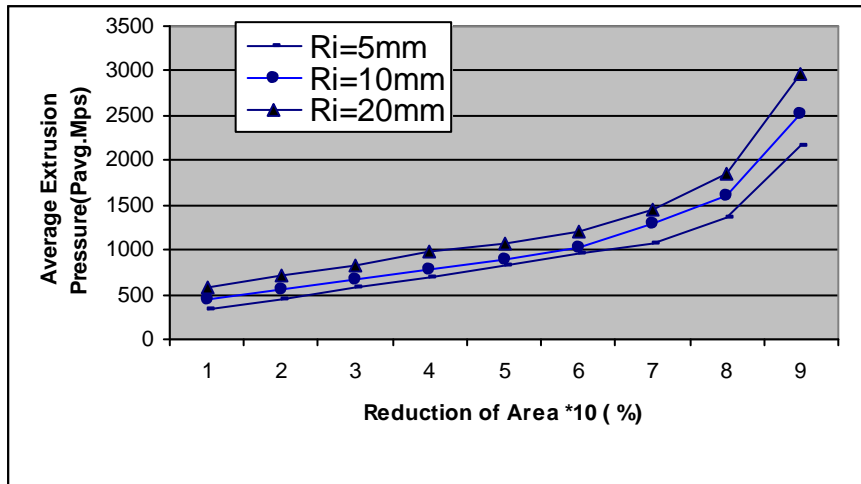

Fig. (7):- Effect reduction of area on the extrusion pressure with different radius

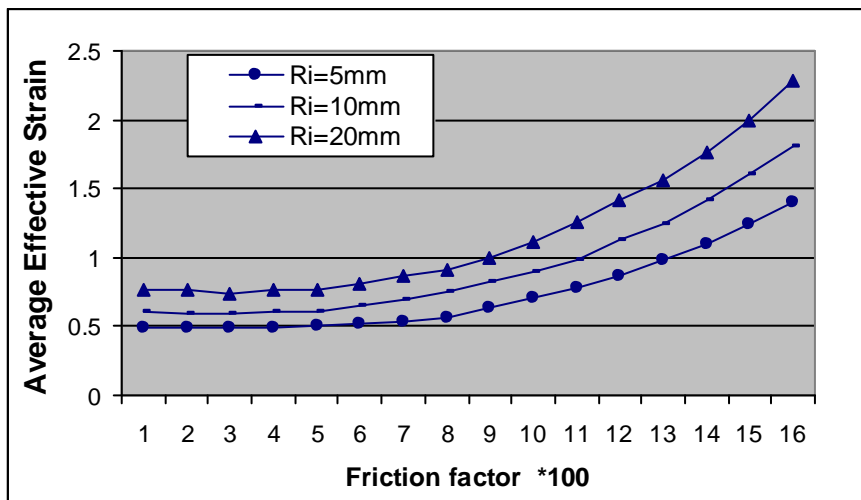

Fig. (8):- Effect of friction on the extrusion pressure and average effective strain with different radius

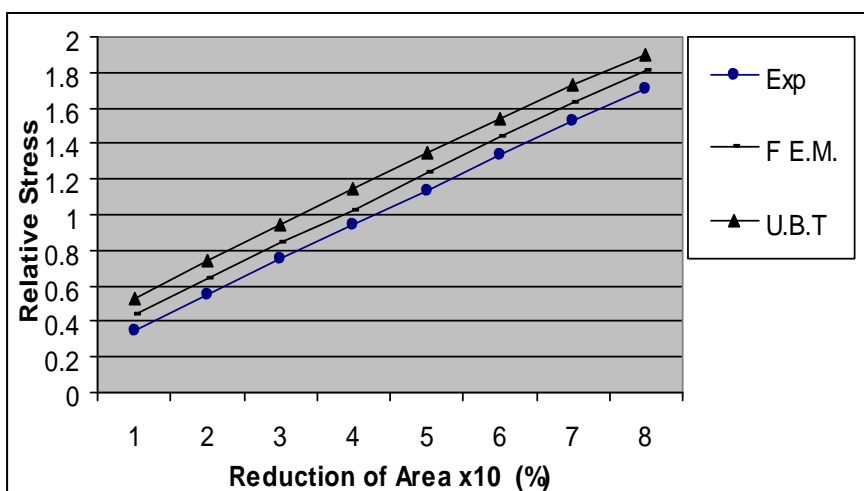

Fig. (9):- Relationships between reduction of area & relative Extrusion stress (Comparison with FEM,U.B.T & Exp results)

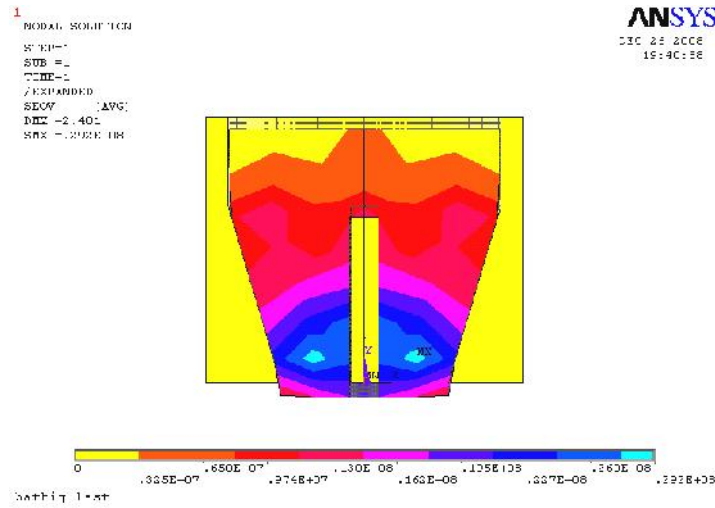

Fig. (10):- Half section show variation of extrusion stress distribution when the reduction of area =80% and (d=13) (mf=0.2)

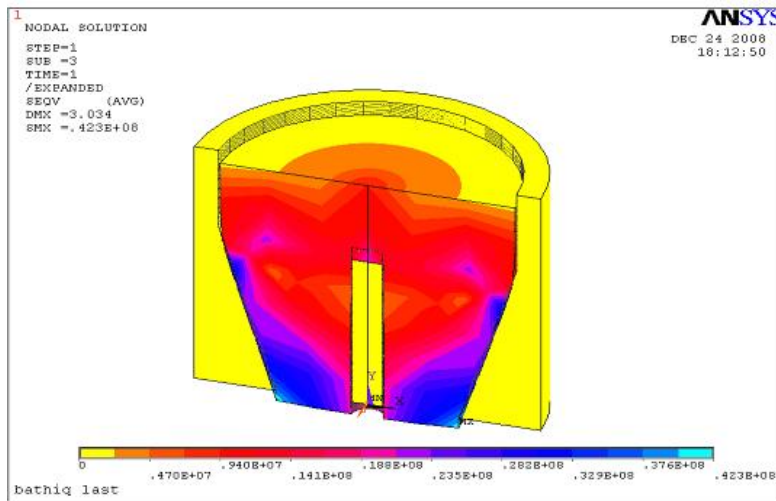

Fig. (11):- Half section show variation of extrusion stress distribution when the Reduction of area =80% and (d=13) (mf=0.3)

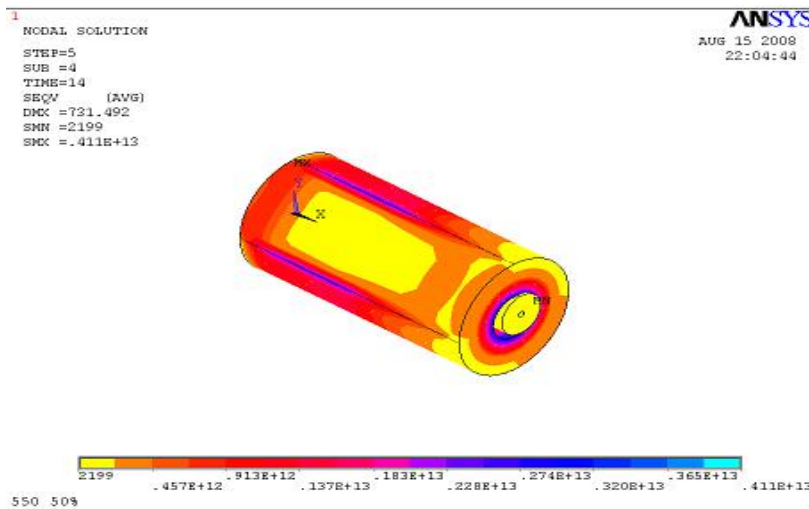

Fig. (12):- Show variation of extrusion stress distribution when the Reduction of area =50% and (d=21.2) (mf=0.1)

INVESTIGATION OF SOME PARAMETERS INFLUENCING OF THREE DIMENSIONAL TUBE EXTRUSION PROCESS OF ELLIPSE SECTION THROUGH STREAMLINE DIE

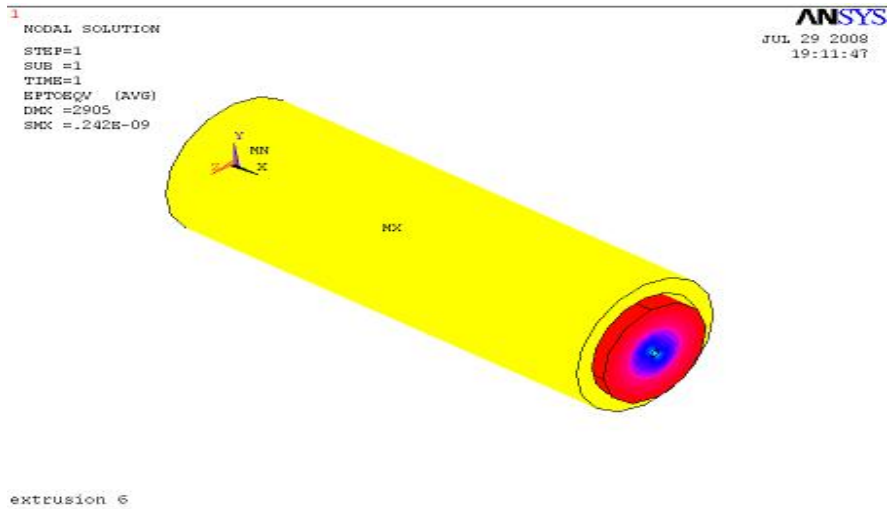

Fig. (13):- full model plastic strain distribution when the reduction of area =30% and (d=25) (mf=0.1 p=300)

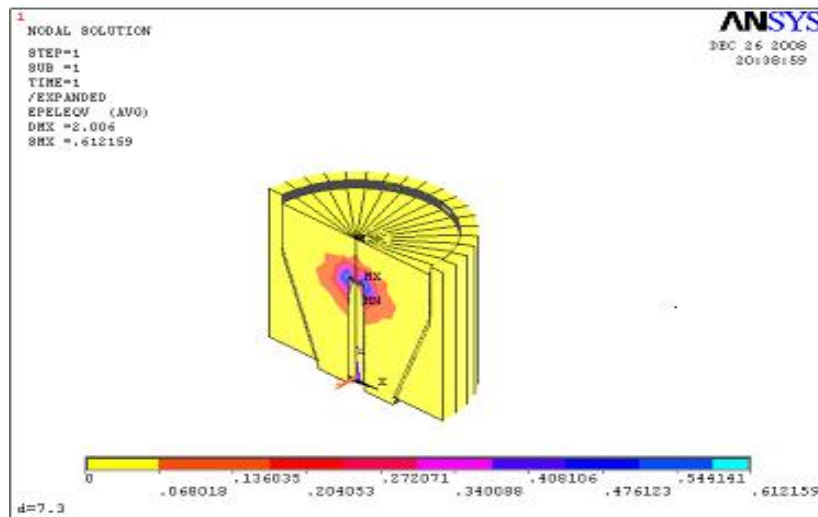

Fig. (14):- Half section elastic strain distribution when the reduction of area = 80%

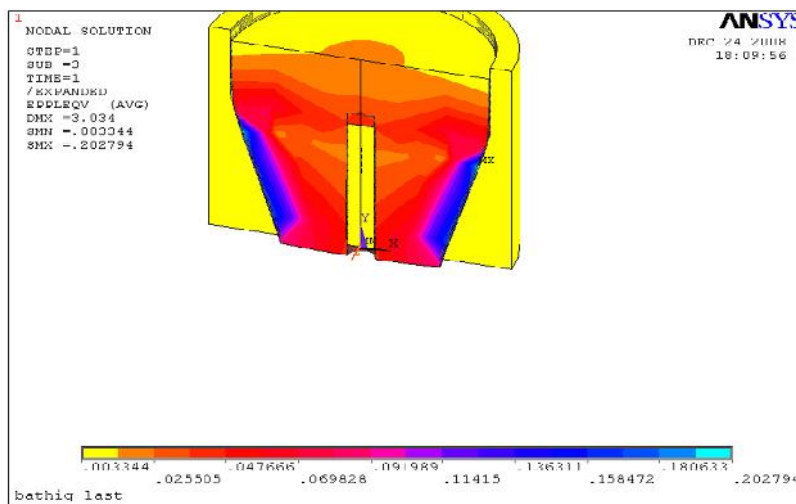

Fig. (15):- Half section plastic strain distribution when the reduction of area = 67 %

دراسة بعض المتغيرات المؤثرة على عملية بثق ثلاثي الأبعاد لأنبوب بيضوي المقطع خلال قالب انسيابي

إخلاص عيدان قادر

د.سعد ذياب فارس

مدرس مساعد

أستاذ مساعد

كلية الهندسة . جامعة ديالى

كلية الهندسة . جامعة ديالى

الخلاصة

في عملية البثق على البارد والتزيت لأنبوب بيضوي المقطع ان الخواص والأسطح الكافية للمنتج تتأثر بالشكل الهندسي للقالب لذا في هذه الدراسة تم تحليل مركبات السرعة في منطقة التشوية اللدن وسط المقطع وعبر عنها كدالة عامة لكي يسمح بوصف الأبعاد الثلاثية لتوزيع الانسياب بمرونة أكثر .

من خلال الاشتقاق لحقل السرعة الحركية وفق نظرية الحد الأعلى إن ضغط البثق تم الحصول عليه من خلال عملية التماثل وفق المتغيرات المعطاة للمادة والانفعالات المؤثرة تم حسابها من اجل دراسة جزء التصليد الانفعالي لمنتجات البثق وكذلك بطريقة العناصر المحددة (F.E.M) من خلال برنامج (Ansys11) لبناء نموذج القالب والتحميل والحل العددي والنموذج المتولد يعتمد على خامة الألمنيوم (٢٠٢٤) تام اللدونة.

في حسابات المنتج بشكل بيضوي المقطع وبتأثير معامل الاحتكاك ، التخصر بالمساحة وطول القالب على ضغط البثق إن انسياب المادة وتوزيع الانفعال المؤثر درست بشكل تفصيلي وان المحاكاة باستخدام برنامج (Ansys11) والإجراءات النظرية لكل من حمل البثق وانسياب المادة كانت متوافقة بشكل جيد مع نتائج مختبرية.