

## **A Modified Method for Calculating Reliability Allocation in Series – Parallel Systems**

Zahir Abdul Haddi Hassan  
University of Babylon-College of Education

### **Abstract:**

In order to improve system reliability, designers may introduce a system of different technologies in parallel. When each technology is composed of components in series, the architecture belongs to the series-parallel systems. This type of system has not been studied as much as the parallel-series ones. There exists no method dedicated to the reliability allocation in series-parallel systems with different technologies. We propose in this paper a study of this reliability allocation problem.

### **المستخلص :**

في هذا البحث تم دراسة مشكلة " تخصيص الثقة " للأنظمة المتسلسلة – المتوازية حيث إن هذا النوع من الأنظمة لم يتم فيه دراسة هذه المشكلة بصورة وافيه كما هو الحال للأنظمة المتسلسلة والمعقدة إذ انه لا توجد طريقة مباشرة لحساب تخصيص الثقة لهذا النوع من الأنظمة . بحثنا هذا تضمن طريقة محددة لحساب تخصيص الثقة لهذه الأنظمة.

### **1. Introduction**

Many researchers work to evaluate the reliability allocation in series, complex systems like Srinath (1985) , Subrie (1996) and Kalia (2004).

The process by which the failure allowance for a system is allocated in some logical manner its sub-systems and elements is **termed reliability allocation**. This problem is different from that determining the system reliability based on individual reliability values of the elements and sub – systems that constitute the system. The purpose of reliability allocation is to establish a goal or objective for the reliability of each component so that the manufacturers can have an idea of the performance required of this product.

### **2. Problem description**

A series – parallel system is composed of (**n**) systems in parallel, where each sub- system is composed of (**m**) components in series.

We get the reliability of such system as

$$R_{system} = 1 - (1 - R_s)^n \quad \dots(1)$$

Where  $R_s = \prod_{i=1}^m r_i$  ,  $r_i$  is the reliability of each component in series ( the exponential distribution is useful model in this work ).

The principle adopted in this method for subdividing the system failure allowance is that the failure allowance of each component is directly proportional to the predicted probability of failure. This rule based on the assumption that the components exhibit a constant failure rate, and if  $\lambda_i$  is the failure rate of component  $i$  ,  $i= 1, \dots , m$  ,  $\lambda_s$  is termed the predicted system failure rate

$$\text{Where } \lambda_s = \sum_{i=1}^m \lambda_i \quad \dots(2)$$

$\lambda_s^*$  be the specified system failure rate which is assumed to be less than  $\lambda_s$ .

To compute the required failure rate for component i which is denoted by  $\lambda_i^*$ ,  $i = 1, 2, \dots, m$ , we use the following equation :

$$\lambda_i^* t = (\lambda_i t / \lambda_s t) \cdot \lambda_s^* t \quad \dots(3)$$

So the reliability goal for the component i is

$$R_i^*(t) = e^{-(\lambda_i^*) t} \quad \dots(4)$$

Therefore the reliability goal for the series – parallel system is

$$R_{system}^* = 1 - \left( 1 - \prod_{i=1}^m R_i \right)^n \quad \dots(5)$$

**illustrative example :**

A system consists of elements A, B, C and D connected as shown in fig (1) , the predicted reliabilities of the components are also shown.

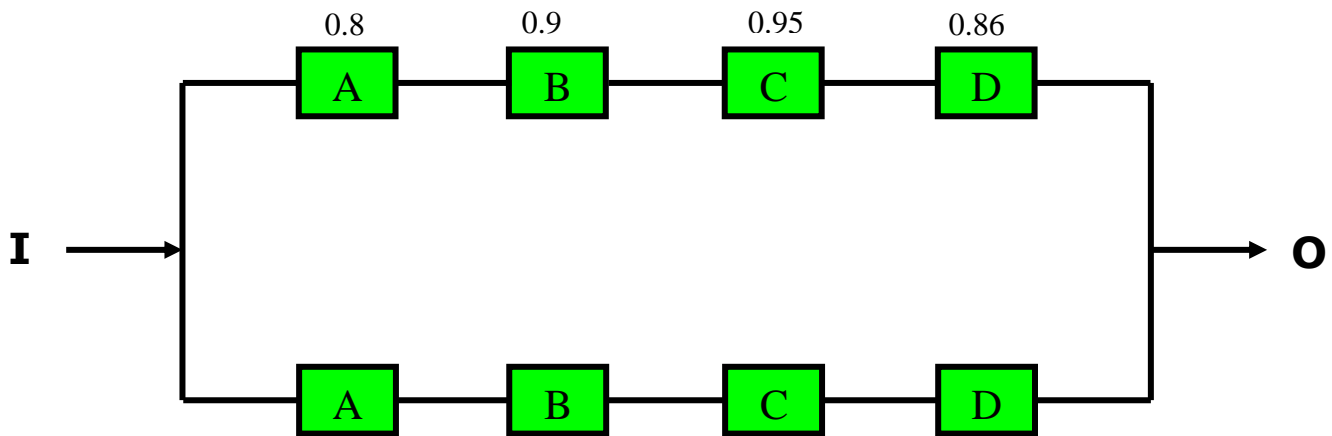

**Figure (1) series – parallel system**

- 1- Calculate the system reliability .
- 2- If the system reliability is to be improved to a value 0.89, determine the reliability goal of each component . Assume constant failure rate of all elements.

**Solution**

1- For calculating the system reliability making use of equation (5) , we get the system reliability for  $m = 4$  and  $n = 2$ .

$$R_S = 1 - (1 - \prod_{i=1}^m r_i)^2$$

$$= 1 - [1 - (0.8 \times 0.9 \times 0.95 \times 0.86)]^2$$

$$= 0.82$$

2- To evaluate the reliability goal of each element we must follow these steps:

**A-** Compute predicted failure rate of each elements

$$R_A = 0.8 \quad \Rightarrow \lambda_A = 0.2$$

$$R_B = 0.9 \quad \Rightarrow \lambda_B = 0.1$$

$$R_C = 0.95 \quad \Rightarrow \lambda_C = 0.05$$

$$R_D = 0.86 \quad \Rightarrow \lambda_D = 0.15$$

By using eq. (2) we get

$$\lambda_S = \lambda_A + \lambda_B + \lambda_C + \lambda_D$$

$$= 0.5$$

**B-** Now we must compute specified system failure rate by making use of eq.(4)

$$\text{Or } R_{system}^* = 1 - \left(1 - e^{-\lambda_s^*}\right)^2 = 1 - \left(1 - e^{-\lambda_s^*}\right)^2$$

$$R_{system}^* = 1 - \left(1 - \prod_{i=1}^m R_i\right)^n \Rightarrow 0.89 = e^{-\lambda_s^*} \Rightarrow \lambda_s^* = 0.66 \Rightarrow = 0.4$$

**C-** If  $\lambda_A^*$ ,  $\lambda_B^*$ ,  $\lambda_C^*$  and  $\lambda_D^*$  are allocated (specified) failure rates, we get

$$\lambda_A^* = (\lambda_s^*/\lambda_s) \lambda_A, \lambda_B^* = (\lambda_s^*/\lambda_s) \lambda_B$$

$$\lambda_C^* = (\lambda_s^*/\lambda_s) \lambda_C, \lambda_D^* = (\lambda_s^*/\lambda_s) \lambda_D$$

**D-** Hence, the allocated reliabilities are

$$R_A^*(t) = e^{-(\lambda_s^*/\lambda_s) \lambda_A}$$

$$R_B^*(t) = e^{-(\lambda_s^*/\lambda_s) \lambda_B}$$

$$R_C^*(t) = e^{-(\lambda_s^*/\lambda_s) \lambda_C}$$

$$R_D^*(t) = e^{-(\lambda_s^*/\lambda_s) \lambda_D}$$

$$R_A^*(t) = e^{-(0.4/0.5) * 0.2} = 0.85$$

$$R_B^*(t) = e^{-(0.4/0.5) * 0.1} = 0.92$$

$$R_C^*(t) = e^{-(0.4/0.5) * 0.05} = 0.96$$

$$R_D^*(t) = e^{-(0.4/0.5) * 0.15} = 0.88$$

### 3. Conclusions

1-The process considered in this paper is the converse of that for calculating the system reliability.

2-If the failure allowance specified for the system is less than the predicted system failure probability, the specified failure allowance is apportioned among the components in some equitable manner.

3-This method used to calculate the reliability allocation for more general structure of series - parallel systems.

### References :

- [1] Srinath L.S., "Concepts in Reliability Engineering" East-West press private Ltd., (1985).
- [2] Subrie U.A. "Some Reliability subject to Corrective Maintenance", M.Sc., university of Baghdad, 1996, Iraq.

### References from internet :

- [3] Jose E. Ramirez-Marquez , David W. Coit and Abdullah Konak , "Redundancy allocation for series-parallel systems using a max-min approach" , 2004 , USA .  
[www.rci.rutgers.edu/~coit/iie-2004.pdf](http://www.rci.rutgers.edu/~coit/iie-2004.pdf).
- [4] Prince Kalia , "Reliability Allocation" , 2004.  
<http://inside.msfc.nasa.gov/midl>.
- [5] The e Magazine for the reliability professional, "Determine reliability for complex systems" , issue2, 2004.  
[www.weibull.com/systemre/web/complex-systems.htm](http://www.weibull.com/systemre/web/complex-systems.htm).