

GENTIC ALGORITHM FOR HARMONICS ELIMINATION

Riyadh M. Naife, Electronic and Communication, M Sc, Assistant teacher at Kerbala University, college of engineering, Electrical and Electronic department.

ABSTRACT

One of the most important problems of power inverter is finding the desired harmonic frequency for representing the transmitted signal with low power consuming, so, to eliminate specific order harmonics, the switching angles must be calculated. There are many methods or techniques used to find optimum switching angles. In this research a new method is used which is a genetic algorithm (GA). GA used to find optimum switching angles which give a certain amplitude waveform with minimum harmonics frequency.

الخلاصة :

واحد من المشاكل الأساسية المهمة في عاكسات القدرة هو إيجاد التردد التوافقي المطلوب لكي يتم تمثيل الموجة المنقلة مع اقل استهلاك للقدرة، لذلك لازالة توافقيات معينة يجب حساب زوايا التحويل. هناك العديد من الطرق والتقنيات استخدمت لإيجاد الحالة المثلى لزوايا التحويل. في هذه البحث تم استخدام طريقة جديدة وهي الخوارزمية الجينية، حيث تم استخدامها لإيجاد الحالة المثلى لزوايا التحويل التي تعطي سعة موجة معينة مع اقل ما يمكن من الترددات التوافقية.

Keyword: Harmonic elimination, GA, PWM, THD, Optimization Methods

1- INTRODUCTION

The contribution of a renewable power source to the total power generation becomes more and more important. A full-bridge inverter is practically always used for interfacing this Green Power Source to the utility-grid.

The control of the energy flowing from the DC source, which is corresponding to an arbitrary renewable power source (wind turbine, photovoltaic cell, fuel cell, etc), to the grid must be done in order to track the maximum power point and to maintain a sinusoidal grid current with low harmonic distortion and a high power factor.

In order to lower the transmitted high frequency current ripple, due to the operation of the inverter, a passive filter consisting of inductors or combination of capacitors and inductors can be inserted between the inverter operating as a stiff voltage source and the grid that operates also as a stiff voltage source [1].

The carrier based Pulse Width Modulation (PWM) methods are the preferred approach in most applications due to the low harmonic distortion waveform characteristics with well defined harmonic spectrum, the fixed switching frequency, and the implementation simplicity. Carrier based PWM methods employ the “per carrier cycle volt second balance” principle to program a desirable inverter output voltage waveform [2,3].

The triangle intersection implementation technique which is increasingly being implemented in digital hardware/software and the direct digital pulse programming technique (always digital software) are the two main methods to match the inverter output voltage with the reference value. The second method was used in this research. A typical block diagram of this method is shown in Fig. (1).

To eliminate specific order harmonics, the switching angles must be calculated. There are many methods or techniques used to find optimum switching angles. In this research a new method is used which is a genetic algorithm (GA). GA used to find optimum switching angles which give a certain amplitude waveform with minimum harmonics frequency.

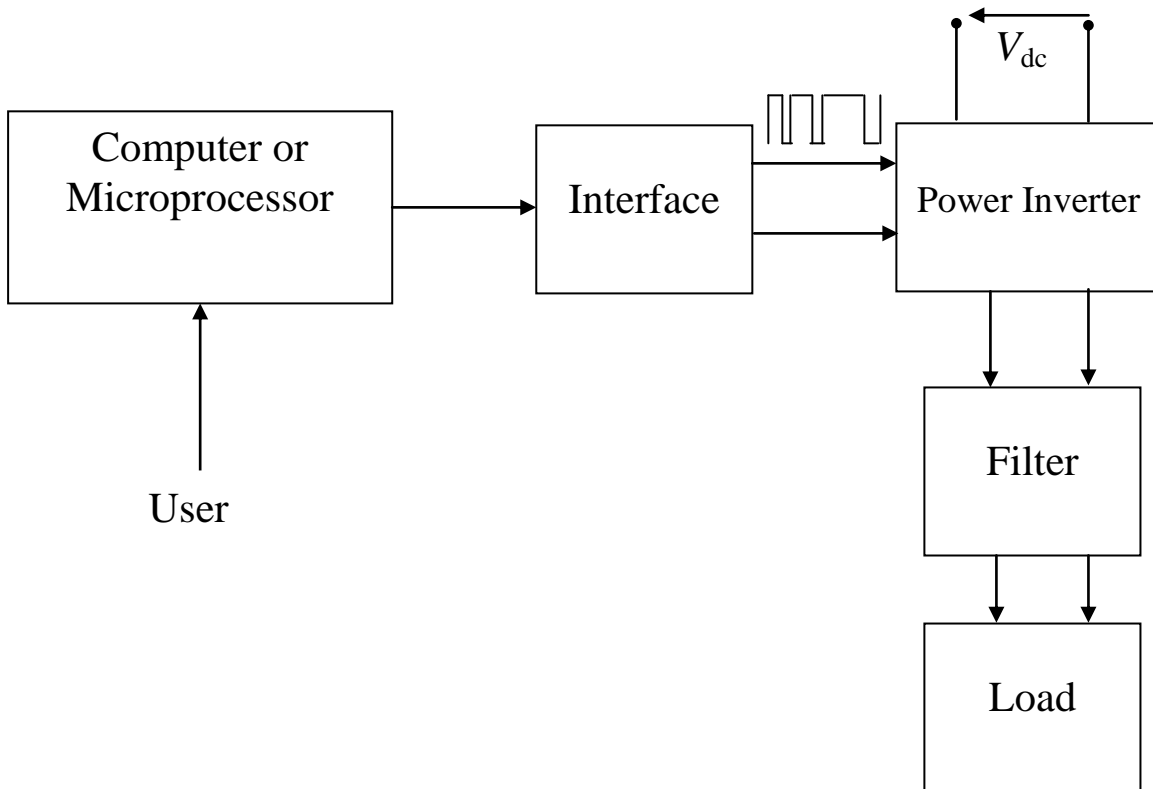

Fig. (1): A typical block diagram of inverter system

2- OPTIMAL PULSE-WIDTH MODULATION.

At a high power level, to limit switching losses of power switches (e.g. GTO's) can only be achieved by switching it at low frequencies (typically several hundred hertz). This implies that only a few switching actions may take place within each fundamental period, as far as the fundamental frequency is not very low. In this case, optimizing the waveform based on specifying an optimal value for each switching instant is necessary for achieving the best modulation result. The high power and cost of the whole system also justify the use of such optimized modulation methods that, in principle, require more advanced (thus more expensive) implementation hardware and software than that of simple carrier-based PWM. The benefits of optimization are also more remarkable, considering the total power of the system.

As the total energy of harmonics contained in a PWM waveform is constant that depends only on the fundamental amplitude, regardless of the actual waveform structure, optimizing the waveform implies not eliminating or reducing the total harmonic energy, but altering its distribution among different frequency components. Considering that most electrical as well as mechanical systems feature some kind of low pass characteristics, low order harmonics are usually considered to be more harmful than high order ones, thus they need to be controlled at smaller magnitudes. Hence, roughly speaking, the objective of optimal PWM is to push most harmonic energy into high-frequency regions such that low-frequency harmonics are well attenuated [2, 3, 4].

2.1 Harmonics Elimination.

One frequently studied optimal PWM method is the harmonic elimination technique, which aims at the complete elimination of some low-order harmonics. The underlying principle of harmonic elimination is that the fundamental and harmonic amplitudes of a symmetrical PWM waveform are nonlinear functions of the N switching angles in the first quarter fundamental period. Setting the fundamental amplitude to a pre-specified value and other $(N-1)$ low-order harmonics equations to zero results in a system of N nonlinear equations. The desired optimal pulse patterns can thus be determined by solving these equations. Two major advantages of applying this technique [3]:

- 1) If the inverter is used to supply ac power of constant frequency to general ac loads, a filter is usually installed at its output. In this case, when low-order harmonics are eliminated through the modulation of the inverter, only high-order harmonics will appear at the output and need to be attenuated by the filter. The cut-off frequency of the filter can thus be increased, leading to a significant reduction of the filter size. System efficiency also tends to increase.
- 2) When used in an ac drive system, eliminating the low-order harmonic voltage leads to great reduction of low-order harmonic torques generated by the motor. Although harmonic torque is the results of interacting between stator and rotor harmonic currents of different order, higher-order harmonic currents have smaller magnitudes due to the larger impedance that the motor presents to higher-order harmonic voltages. Their contributions to lower-order harmonic torques are thus less significant. Lower-order harmonic torques generated by the motor are thus greatly reduced.

2.2 Waveform and Equations

Only two-level line-to-neutral (LN) voltage waveforms are considered in this research. To ensure the absence of even-order harmonics, each waveform is assumed to be quarter-period symmetrical and half-period inversely symmetrical. The waveform is normalized by half of the dc-link voltage such that it has two discrete levels $+1$ and -1 . The maximal fundamental amplitude of such a waveform thus is $4\pi^{-1}$, which is achieved when no modulation takes place in each half-wave period.

Two basic structural alternatives of two-level PWM waveform to be considered in this object are shown in Fig. (2). They will be referred to as LN1 and LN2 waveform for single and three-phase applications; they are denoted as SLN1, SLN2, TLN1, and TLN2, respectively [3].

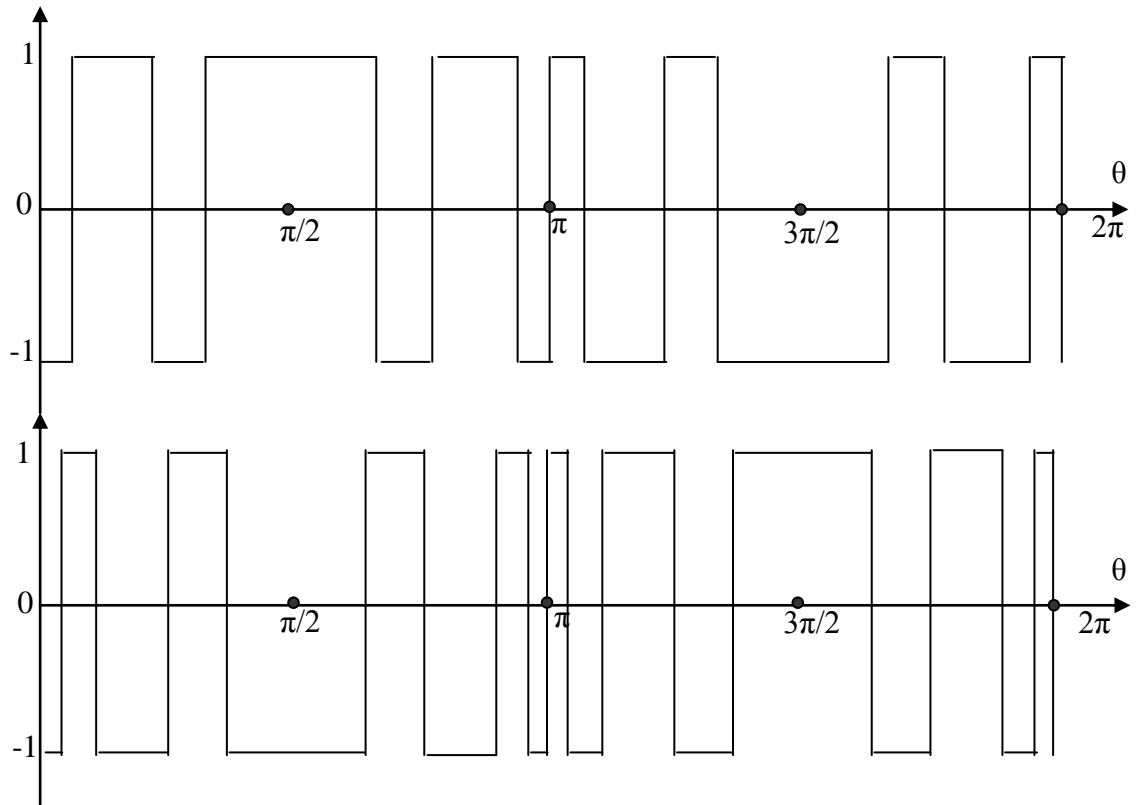

Fig. (2): Structural Alternatives of Two-Level PWM Waveforms

2.3 Waveform Representation.

Asymmetrical PWM waveform with a given structure will be uniquely determined if the N switching angles in the first quarter period are specified. Evidently, these angles must satisfy the basic constrain

$$0 \leq \alpha_1 \leq \alpha_2 \leq \dots \leq \alpha_{N-1} \leq \alpha_N \leq \frac{\pi}{2} \tag{1}$$

For each waveform, we use a $(N+1)$ -dimensional vector $h = [h_0, h_1, h_2, \dots, h_N]^T$ to represent its initial level at $\theta = 0$ and the variation of level at all N switching instants. That is

$h = [-1, 2, -2, \dots, 2]^T$ for LN1 waveforms.

$h = [1, -2, 2, \dots, -2]^T$ for LN2 waveforms.

Based on these notations, Fourier representation of a PWM waveform introduced above can be easily determined to be

$$f(\theta) = \sum_{k=0}^{\infty} V_{2k+1} \sin[(2k+1)\theta] \tag{2}$$

Where V_{2k+1} is the amplitude of the $(2k+1)$ the harmonic voltage ($k=0, 1, 2, \dots$)

$$V_{2k+1} = \frac{4}{(2k+1)\pi} \left[h_0 + \sum_{i=1}^N h_i \cos[(2k+1)\alpha_i] \right] \tag{3}$$

3- GENETIC ALGORITHM(GA)

The genetic algorithm (GA) is an optimization and search technique based on the principles of genetics and natural selection. A GA allows a population composed of many individuals to evolve under specified selection rules to a state that maximizes the “cost function”.

Optimization in GA means maximization. In cases where minimization is required, the negative or the inverse of the function to be optimized is used.

The GA begins, like any other optimization algorithm, by defining the optimization variables and the cost function. It ends like other optimization algorithms too, by testing for convergence. In between, however, this algorithm is quite different [5,6,8].

3.1 Selecting the Variables and the Cost Function

A cost function generates an output from a set of input variables (a chromosome). The cost function may be a mathematical function, an experiment, or a game. The object is to modify the output in some desirable fashion by finding the appropriate values for the input variable

The GA begins by defining a chromosome or an array of variable values to be optimized. If the chromosome has N_{var} variables (an N_{var} -dimensional optimization problem) given by $\alpha_1, \alpha_2, \dots, \alpha_{Nvar}$ then the chromosome is written as an N_{var} element row vector.

$$\text{Chromosome} = [\alpha_1, \alpha_2, \dots, \alpha_{Nvar}]$$

Each chromosome has a cost found by evaluating the cost function,

f , at $\alpha_1, \alpha_2, \dots, \alpha_{Nvar}$:

$$\text{Cost} = f(\text{chromosome}) = f(\alpha_1, \alpha_2, \dots, \alpha_{Nvar})$$

The cost function is written as the negative of the elevation in order to put it into the form of a minimization algorithm [10]:

$$\text{Cost} = -f(\alpha_1, \alpha_2, \dots, \alpha_{Nvar})$$

3.2 Encoding

A chromosome should in some way contain information about solution that it represents.

The most used way of encoding is a binary string. For example

$$\alpha_1 = [1101\dots0101]$$

$$\alpha_2 = [1011\dots1001]$$

.....

$$\alpha_n = [0011\dots1011]$$

where each bit is called genes

3.3 The Population

The GA starts with a group of chromosomes known as the population. The population has N_{pop} chromosomes and is an $N_{pop} \times N_{bits}$ matrix filled with random ones and zeros. If the range of the chromosomes is known then it can be considered for initialization. The narrower the range, the faster GA converges

3.4 Selection

Survival of the fittest translates into discarding the chromosomes with the highest cost. First, the N_{pop} costs and associated chromosomes are ranked from lowest cost to highest cost. Then, only the best are selected to continue, while the rest are deleted. The selection rate, X_{rate} , is the fraction of N_{pop} that survives for the next step of mating. The number of chromosomes that are kept each generation is

$$N_{keep} = X_{rate} \times N_{pop}$$

3.5 Mating

Mating is the creation of one or more offspring from the parents selected in the pairing process. The genetic makeup of the population is limited by the current members of the

population. The most common form of mating involves two parents that produce two offspring. A crossover point, or kinetochore, is randomly selected between the first and last bits of the parents' chromosomes. First, $parent_1$ passes its binary code to the left of that crossover point to $offspring_1$. In a like manner, $parent_2$ passes its binary code to the left of the same crossover point to $offspring_2$. Next, the binary code to the right of the crossover point of $parent_1$ goes to $offspring_2$ and $parent_2$ passes its code to $offspring_1$. The chromosomes undergoing crossover are paired randomly.

For example if x_1 and x_2 are paired then:

Before crossover

$$\alpha_1 = [1101010101]$$

$$\alpha_2 = [1011011100]$$

and after mutation,

$$\alpha_1 = [1011010101]$$

$$\alpha_2 = [1101011100]$$

It is obvious that the first five bit is exchange between tow chromosomes.

3.6 Mutations

Mutation operation randomly changes the offspring resulted from crossover. Mutation is intended to prevent falling of all solutions in the population into a local optimum of the solved problem.

A single point mutation changes a 1 to a 0, and visa versa. Mutation points are randomly selected from the $N_{pop} \times N_{bits}$ total number of bits in the population matrix. Increasing the number of mutations increases the algorithm's freedom to search outside the current region of variable space. It also tends to distract the algorithm from converging on a popular solution. Mutations do not occur on the final iteration.

For example assume that the 2nd bit of α_1 and 5th bit of α_2 need to mutate then:

Before mutated

$$\alpha_1 = [1101010101]$$

$$\alpha_2 = [1011011100]$$

after mutated

$$\alpha_1 = [1001010101]$$

$$\alpha_2 = [1011111100]$$

After the mutations take place, the costs associated with the offspring and mutated chromosomes are calculated .The process described is iterated.

The number of generations that evolve depends on whether an acceptable solution is reached or a set number of iterations is exceeded. After a while all the chromosomes and associated costs would become the same if it were not for mutations. At this point the algorithm should be stopped [5,6].

4- FILTER

Various types of filter used are shown in Fig. (3).In single **LC** filter, the inductor **L** offers high reactance for higher frequencies. The high frequency components are dropped across **L**. The capacitor **C** offers high reactance for low frequencies. By selecting a large **L** the drop increases and the output voltage reduces on load. By choosing large **C**, high frequency components can be shunted through **C**. This increases the current rating of the inverter devices.

With single **LC** filter some harmonics manage to pass to the load. The harmonics can be further reduced by going for multiple filters. The size of filter inductor can be reduced by connecting it across the secondary of a step down transformer.

If the inverter operates at fixed frequency, series **LC** filter can be used. The values of **L** and **C** are chosen such that their natural frequency is equal to the output frequency of the inverter.

The filter and load resistance operate as series resonant circuit. The current is in phase with the output voltage. Therefore the voltage across the load resistance is sinusoidal [9].

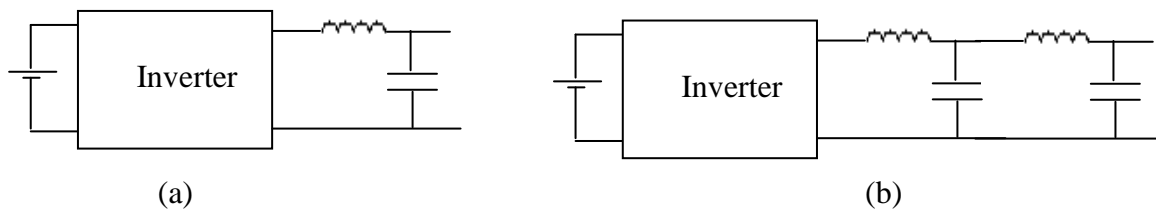

Fig. (3): a) Single L.C Filter
b) Multiple L.C Filter

5- THE GA IMPLEMENTATION

In previous section, the genetic algorithm had been explained in general however the main steps can be applied for any application. In following section there are steps which explain how we can use GA for PWM.

1- Chose the number of variable. In PWM the number of variable is the number of controllable switching angle. In this application we will study performance of system when we use 3, and 4 switching angles.

2- Initialize the population size. In our application the population size of 20 is selected. With higher population size, the region of search will increase but might increase the rate of convergence and execution time.

The population is initialized with random angles between 0 and $\pi/2$ taking into consideration the quarter-wave symmetry of the output voltage waveform. If the ranges of each chromosome are known it can be set to decrease the execution time. The default range is between [0, 1]

3- Selection the cost function to be minimized. It is the most important item for GA. The chose of cost function depended on what condition is needed. In PWM objective the main problem is how to minimize the harmonics especially which has low-order harmonics while the high-order harmonics can be eliminated by any simple first order filter.

If the 3rd, 5th and 7th harmonics of the output of two-level inverter have to be minimizing (the even harmonics are ordinary eliminated because the wave is half and quarter-symmetry), the cost function must be related to these harmonics. Therefore the cost function is the sum of three harmonics normalized to the fundamental.

$$f(\alpha) = 10 \times \frac{|V_3| + |V_5| + |V_7|}{|V_1|} \tag{4}$$

or

$$f(\alpha) = |V_3| + |V_5| + |V_7| - |V_1| \tag{5}$$

where α are the switching angles, V_1 is the fundamental voltage and V_n are the nth order voltage harmonics.

According to eq.(4) or eq.(5) ,by using switching angle we can calculate the magnitude voltage for each harmonics and a output waveform can be drawn depended on these switching angle .

It obvious from above cost function, we can get maximum fundamental voltage with minimum harmonic voltages but we cannot get certain amplitude of fundamental frequency. So we need to modify the cost function to obtain specific magnitude of output waveform. Assume that we need output voltage waveform equal M , then the new cost function will be:

$$f(\alpha) = |V_3| + |V_5| + |V_7| + |V_1 - M|$$

where M is called modulation index.

4- when GA apply on this cost function as minimize for first iteration then the lowest cost with associated chromosomes are selected to continue, while the rest are deleted. After that a mating and mutation are applied to get a new population which goes through the same cycle starting from cost function evaluation.

The number of iteration is deferent from one to other. Sometimes, it converges to a solution much before 100 iterations are completed. The flowchart of GA is shown in Fig.(4).

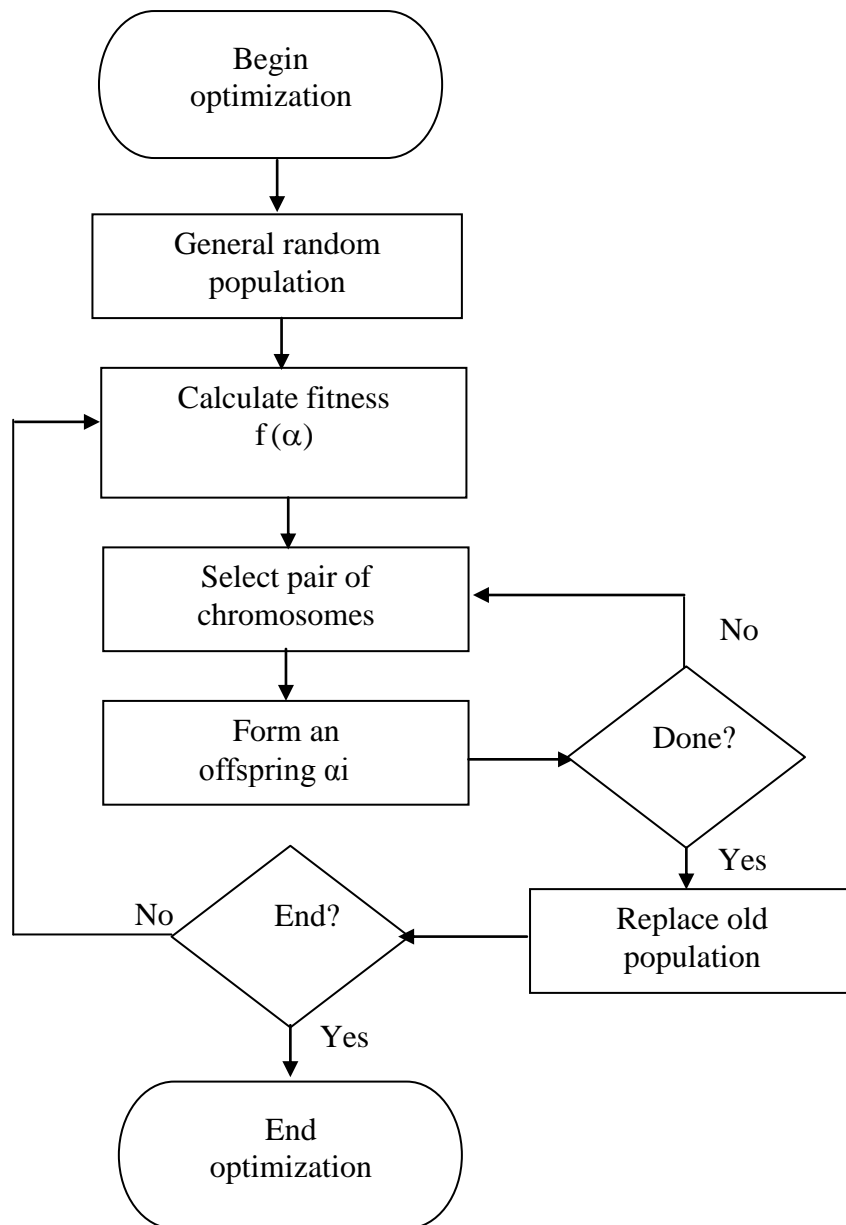

Fig. (4): genetics algorithm flowchart

6-THE RESULTS

In our object the MATLAB program was used to apply GA. The GUI was used as optimization toolbox and the M-file was used to draw the relation of switching angles and total harmonic distortion (THD) with respect to modulation index.

For the inverter with three switching angles which minimize the 3rd, 5th and 7th are shown in Fig.(5(a)). When we use the same initial population and apply GA for deferent value of M then we get the path of three angles as shown in the figure. If we use other initial population and repeat the GA for deferent M then we get anther path of the angles and each angle have the same rang of previous cases. Note that the GA use random solution to obtain the optimum case so that, form the Fig.(5(a)), the path of angles can not be linear or curve lines but as random path with limited range for each angle and any set of angles satisfy optimum solution of cost function. The related THD of each set of solution is shown in Fig.(5(b)). The same algorithm applied for inverter with four switching angles. The relation between angles and M are shown in Fig.(6(a)) and the related THD is shown in Fig.(6(b)). The effect of single LC filter with transfer function as shown in eq.(6) is considering in this research.

$$\frac{V_o}{V_{in}} = \frac{\omega^2}{\omega^2 - \omega_s^2} \tag{6}$$

where the cut off frequency (ω_s) is

$$\omega_s = \frac{1}{\sqrt{LC}}$$

The amplitudes of harmonics are shown in Fig. (7(a)) with $M = 1.6$ and $\omega_s = 1.5 \omega_1$ (fundamental frequency). The related output waveform is shown in Fig.(7(b)).

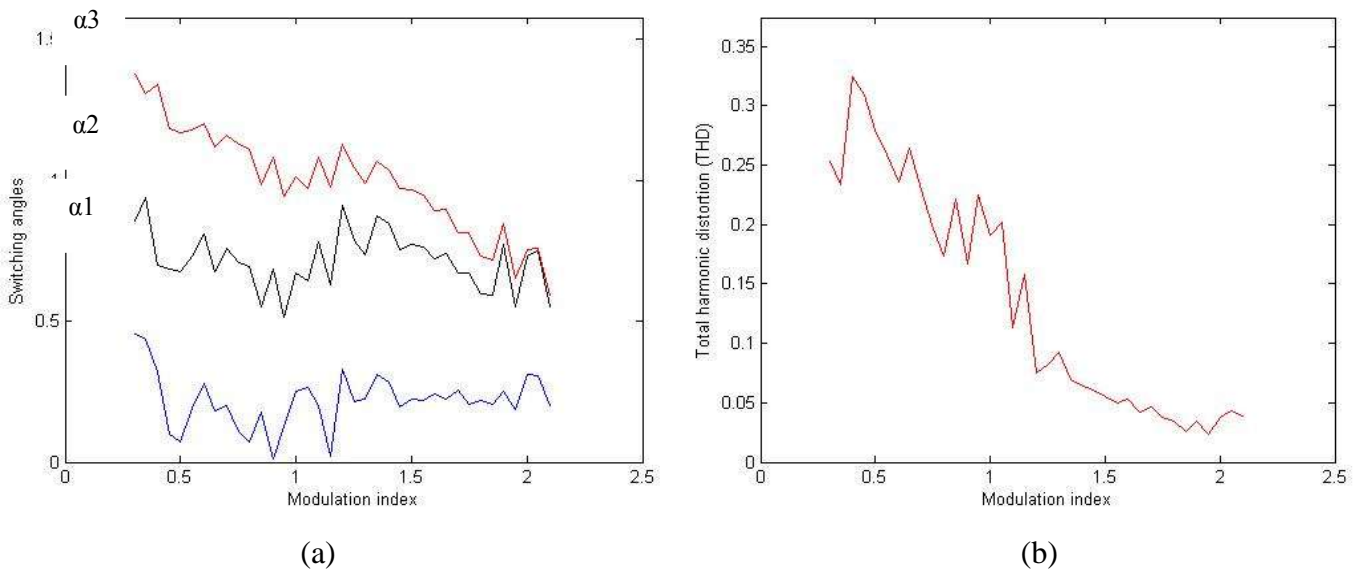

Fig.(5): a) Switching angles ($\alpha_1, \alpha_2, \alpha_3$) for deferent M .
 b) THD for deferent M

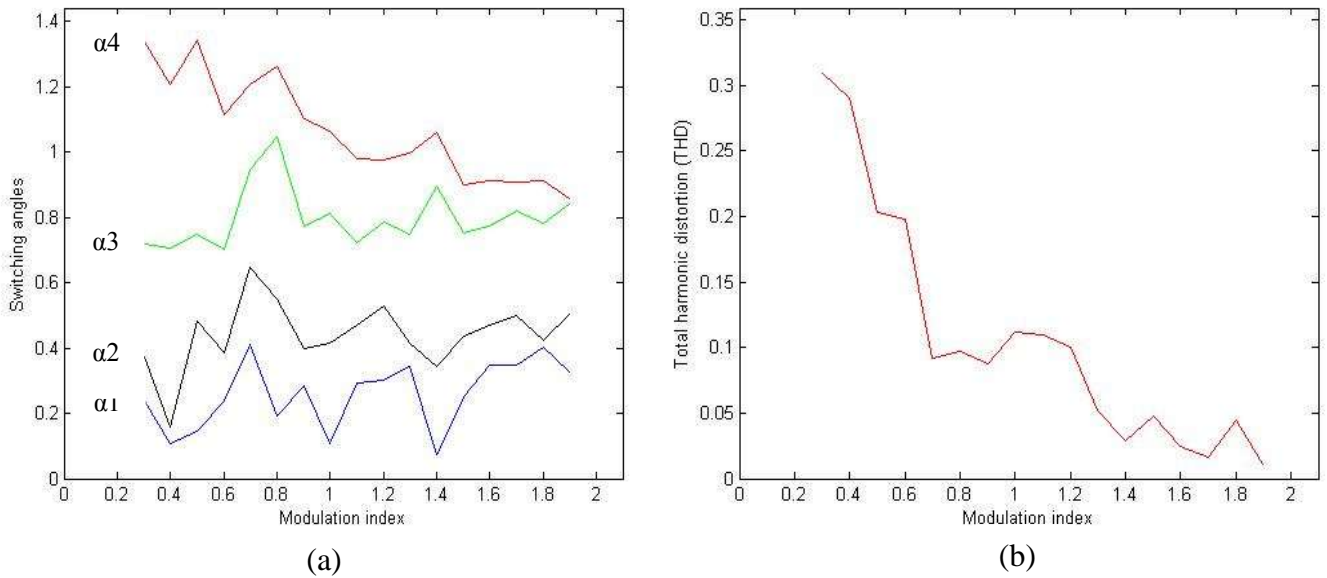

Fig.(6): a) Switching angles ($\alpha_1, \alpha_2, \alpha_3, \alpha_4$) for different M .
b) THD for different M

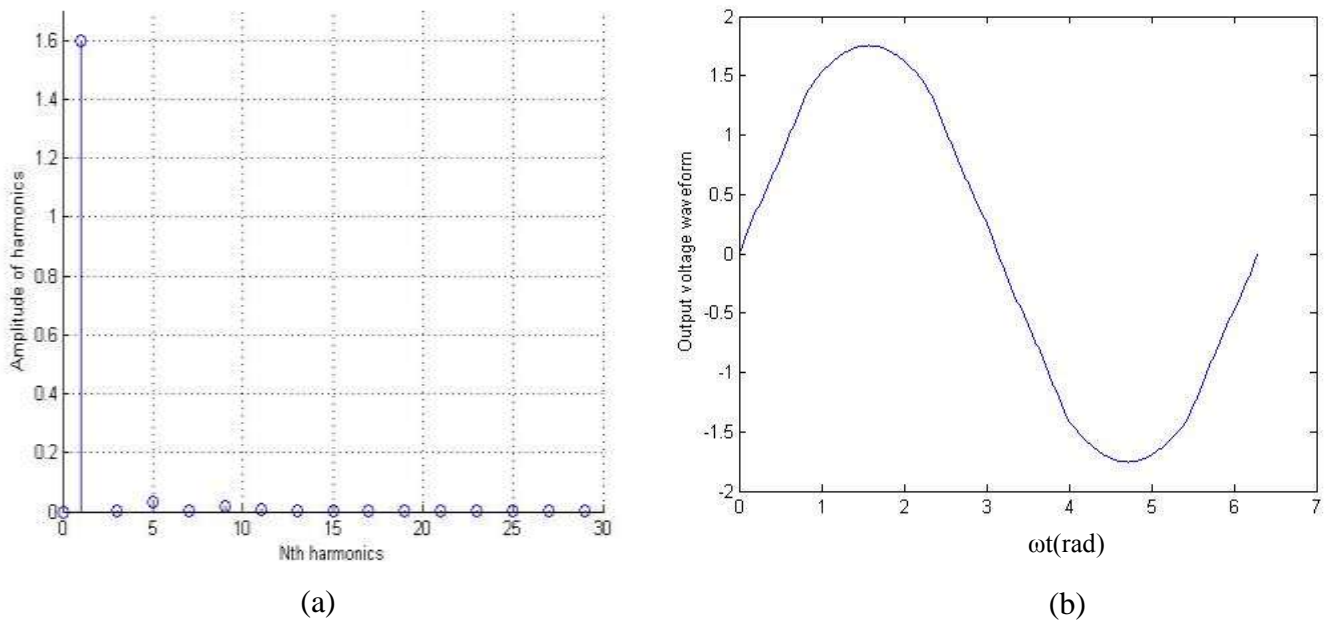

Fig.(7): Three switching angles inverter ($M = 1.6$)
a) Amplitude of harmonics.
b) Output voltage waveform.

7-Conclusion

For single-phase bridge inverter operating with PWM. The harmonics components appeared in the frequency spectrum are the odd harmonics only. Higher order even harmonics as well as the sub harmonics are not present.

In this method it is easy to be implemented (i.e. it doesn't need any condition to implement) and give best performance characteristics due to the lowest harmonic content of the output

voltage waveform and also due to the drastic reduction in the higher order harmonics, as well as significant transfer of harmonic energies to the fundamental component.

In other methods, the number of harmonics eliminated can be achieved by choice the number of triggering angle, for example, when we need to eliminated the 3rd and 5th harmonics, then we use three triggering angle (α_1, α_2 and α_3) and for eliminated 3rd, 5th and 7th harmonics, then we use four triggering angles and so on [3,10].while in this method, the number of harmonics eliminated is not depended on the number of triggering angle (i.e. we can eliminate any number of harmonics depended on three triggering angle (α_1, α_2 and α_3).The advantage of decreasing the number triggering angles is that, the harmonic components which are generated by switching action will be decreased.

References:

- [1] Mustapha Raou, Moulay Tahar Lamchich "Average Current Mode Control Of A Voltage Source Inverter Connected To The Grid: Application To Different Filter Cells" Journal of Electrical Engineering, VOL. 55, NO. 3-4, 2004, 77-82
- [2] J.Holtz, "Pulse Width Modulation for Electronic Power Conversion", IEE Proc.,vol.82,no.8,Aug.,1994.
- [3] J.Sun, S.Beinck and H.Grotstollen, "Optimal PWM Based on Real-Time Solution of Harmonic Elimination Equations", IEEE Trans. Power Electronics, vol.11, no.4, July, 1996.
- [4] J.H.Matheus and K.D.Fink, "An Improved Weighted Total Harmonic Distortion Index for Induction Motor Drives", University of Wisconsin, NewYork, 2000.
- [5] -W. Leo Meerts, Michael Schmitt, and Gerrit C. Groenenboom "New applications of the genetic algorithm for the interpretation of high-resolution spectral" © 2004 NRC Canada.
- [6] A. Rangel-Merino, J. L. López-Bonilla, R. Linares y Miranda "Optimization Method based on Genetic Algorithms" *Apeiron*, Vol. 12, No. 4, October 2005
- [7] Andrew Chipperfield, Peter Fleming, Hartmut Pohlheim and Carlos Fonseca "Genetic Algorithm Toolbox" For Use with MATLAB
- [8] Randy L. Haupt, Sue Ellen Haupt "Practical Genetic Algorithms "2sd edition, John Wiley & Sons, 2004.
- [9] S. Rama Reddy, "Fundamentals of Power Electronics", book, Copyright ©2000
- [10] T. Jun Liang, M.O Connell and G.Hoft, "Inverter Harmonic Reduction Using Walsh Function Harmonic Elimination Method", IEEE Trans. Power Elec.,vol.12,no.6,Nov.1997.