

## *Investigation of Steel-Concrete Composite Beams with Different Types of Shear Connectors*

**Dr. Suhaib Y. K. Al-Darzi, Lecturer**      **Inas M. A. Al-Juboory, Assistant Lecturer**  
**Civil Engineering Department**      **Department of Mechanics and Equipment**  
**University of Mosul**      **Technical Institute-Hawija - Kirkuk**

### **Abstract**

A ten steel-concrete composite beams subdivided into five groups formed from standard steel section (W4X13) connected to concrete slab are designed and constructed using three different types of mechanical shear connectors. A stud connector and regular circular hole perfobond connectors are used in addition to a newly suggested type of triangular hole perfobond connector. The beams are experimentally tested using two point load beam test to investigate the effect of connector's type on beam resistance at yielding and ultimate stages. The tests also investigate the deflection at mid-span and slip at the ends of the tested beams. It is found that the composite beams with perfobond connectors can develop a strength higher than those obtained with stud connectors, as well as the newly suggested triangular perfobond connector gives strength higher than the regular circular perfobond. Results also show that, continuous distribution of perfobond connectors give resistance more than those with separated perfobond connectors.

**Keywords:** Shear connector, Composite beam, Perfobond, Stud connector, beam test.

### **تحري سلوك العتب المركب حديد - خرسانة باستخدام أنواع مختلفة من روابط القص**

#### **الخلاصة**

في الدراسة الحالية تم تصميم وتنفيذ عشرة أعتاب حديدية مركبة قسمت الى خمسة مجموعات وباستخدام ثلاثة أنواع من روابط القص، حيث تم استخدام الرباط المسماري والروابط المثقبة الدائرية الفتحات مع اقتراح نوع جديد من الروابط المثقبة مثلثة الفتحات. تم إجراء فحص نقطتي تحميل على هذه الأعتاب لغرض تحري تأثير نوع الرباط لمستخدم على تصرف ومقاومة الأعتاب المركبة حديد-خرسانة في مرحلتي الخضوع والفسل. تم تسجيل الهطول في منتصف العتب والانزلاق في النهايات لمعرفة مقدار التغيرات الذي يحصل فيهما نتيجة استخدام الأنواع المختلفة من روابط القص. وقد وجد من خلال البحث أن العتب المركب الذي يستخدم روابط قص مثقبة يعطي مقاومة أقوى من تلك التي تستخدم الروابط المسمارية، كما أن النوع الجديد الذي تم اقتراحه من الروابط المثقبة المثلث الفتحات يعطي مقاومة أعلى من الروابط المثقبة دائرية الفتحات. كما بينت النتائج أيضاً أن استخدام الروابط المثقبة بشكل مستمر يعطي مقاومة أعلى من استخدامها بشكل منفصل.

**الكلمات الدالة:** روابط قص، العتب المركب، روابط مثقبة، روابط مسمارية، فحص العتب.

## Introduction

Nowadays, composite steel-concrete structures are used widely in modern bridge and building construction. The steel I-section beam connected to concrete slab is one of the most commonly used composite beams, which is mainly used due to a reduction in construction depth, savings in steel weight and rapid construction.<sup>[1]</sup> The main advantages of composite beam is gained when having an efficient connection between steel and concrete. The horizontal shear resistance is one of the most important property affects the behavior of composite beam, therefore, several types of shear connectors suggested and developed through the past years to prevent the slip might occurs between concrete and steel. In the present work, the connection between steel and concrete components is attempt to be investigated through investigating five groups of steel-concrete composite beams with three types of shear connectors. Since 1922, several researches were conducted to investigate the behavior of shear connector led to suggesting and developing several types of mechanical shear connectors and enhancing those available.<sup>[1-5]</sup> The interaction between steel girder and concrete deck slab was investigated by Oehlers, et.al.<sup>[6]</sup> considering the effect of partial and full interaction, developed from the horizontal shear force at the interface between steel beam and concrete slab, on the composite beam's behavior aiming to investigate the maximum flexural capacity using a developed computer program.<sup>[6]</sup> In the present work, a test to investigate the behavior of composite beam with three different types of mechanical shear connectors, namely stud, regular perfobond (PB) and newly suggested triangular perfobond (TPB) connectors were conducted. The tests aimed to

investigate the applicability of the newly suggested type of perfobond connector (TPB) in steel-concrete composite beam. The work also included an investigation of the effectiveness of arrangement of the perfobond connectors; therefore, two methods of arrangements, continuous and separated perfobond connectors, are suggested and tested.

## Materials and Method

In the present work, ordinary cement with aggregates having maximum size of 20mm are used in concrete made. The cement, aggregate and water used in concrete are tested and prepared before construction of composite beam samples. A local cement manufactured in Badosh factory in Mosul is used. A physical and chemical tests are conducted to ensure that the cement are comply with the requirements of Iraqi standards, IQSNo.5,1984.<sup>[4]</sup> The chemical and physical tests results of cement are shown in Table 1

A local river sand is used as a fine aggregate in concrete admixture, after making a sieve analysis and fined to within the range of medium sand in accordance with (B.S.882:1992)<sup>[3]</sup>, with a fineness modulus of 2.81 and clay percentage 1.4%, as shown in Figure 1. A local river gravel with maximum aggregate size of 20mm, according to B.S.882:1992<sup>[3]</sup>, having sieve analysis shown in Figure (1) is used as a coarse aggregate in concrete admixture. A normal drinking (tap water) is used for mixing of concrete. Several mixes are prepared to get the required compressive strength of concrete. A mix with percentage (cement: sand: gravel /water) (1:2.46:3.3/0.45) are used with slump of (90mm). The average concrete compressive strength of standard cylinder ( $f_c' = 21N/mm^2$ ) is determined from standard compression tests of six

concrete cubes 150x150x150mm, given as ( $f_{cu}=26.167 \text{ N/mm}^2$ ) by assuming that  $f_c'=0.8f_{cu}$  conducted according to ASTM specification. Steel beams used in the specimen construction are standard hot-rolled steel shape (W4X13), with total length of 1300mm connected to 100mm thickness concrete slab with 200mm width, as shown in Figure (2). An average steel yield strength ( $f_y=331 \text{ N/mm}^2$ ) and ultimate strength of ( $f_{ult.}=465 \text{ N/mm}^2$ ) are obtained from uniaxial tensile test of six samples taken from flange and web of steel section. The same test is used for 10mm diameter reinforcement bars and found that the yield strength ( $f_y=562 \text{ N/mm}^2$ ) and ultimate strength of ( $f_{ult.}=675 \text{ N/mm}^2$ ). The results of steel section, reinforcement and concrete strength are shown in Table(2). The Extensometer is used to measure the displacement during the uniaxial tensile tests of steel sections and from the stress-strain relationships, as shown in Figure (3), the modulus of elasticity are found to be  $E_{ss}=194350 \text{ MPa}$  and  $E_{sr}=187330 \text{ MPa}$  for steel section and steel reinforcement respectively. Steel connectors used in the specimen construction are headed stud shear connector (12.5mm diameter, and 80mm height), perfobond connectors with circular holes, (thickness=4mm, height=80mm, and hole diameter = 40mm) and perfobond connectors with triangular holes, (thickness =4mm, height=80mm, and hole base=50mm, hole height=50mm), as shown in Figure (4). An average yield strength and ultimate strength of each type of connectors are obtained from uniaxial tensile test as listed in Table (3).

The experimental work considered the effect of using different types of shear connectors, by using headed stud, circular/regular perfobond and newly suggested triangular perfobond, and method of distribution of perfobond

connectors on slip and deflection of composite beam. Therefore, a total of ten composite beams are tested in the civil engineering laboratory, in Mosul university. The beams are separated into five groups, each has two beams. One group contain a two composite steel beams with seven headed stud shear connector, also, two groups are constructed with beams have a circular perfobond connectors, using two method of connectors' placement (placing connectors continuously and separating the connectors individually). As well as, another two groups containing composite beams with the newly suggested triangular perfobond connectors are constructed using the same method of connectors' placing (continuous and separately). The test groups are summarized in Table(4). The shear connectors are welded to the steel beam by qualified welders, following a standard procedure. A minimum number of rebar with diameter of 10mm are used as a reinforcement in the concrete flange for both longitudinal and transverse directions. The concrete flanges are formed with wood forms, as shown in Figure (5), and cast at the laboratory. After concrete casting the concrete surfaces of the beams were kept moist with wet burlap for 3 days. The wood forms are then removed and the specimens are cured in air-dry conditions until testing. The composite beam specimens are supported at its ends, with span *1200mm* between supports. A *500kN* hydraulic jack is used to apply a two points load test with a monotonic load applied at the top of concrete flange through a distribution beam and two cross shafts, generating the loading condition shown in Figure (6). The test setup generates a two shear spans near the ends and a pure bending span in the middle of the simply supported beam. The load is gradually applied and

monitored and recorded using a load cell against the slip at ends and deflections at mid-span, recorded using three transducers with an accuracy of (0.0001mm).

### Results and Discussions

During testing of the specimens, a diagonal shear cracks are observed at the bottom of the concrete flange of most specimens, these cracks are initiated at different load stages, then extended further and corresponded to the increasing of the load applied. Small flexural cracks at the middle portion are developed and observed in some specimens. The final failure modes of all specimens are the shear failure in concrete flange after generating major shear cracks, as shown in Figure (7). The tested groups and test results listed in Table (4), show that the composite beams with the newly suggested triangular perfobond connector (*BTPB-Group*) give the highest yield strength and the highest average ultimate strength, while the beams with headed stud shear connectors (*BHS-Group*) give the lowest yield strength and lowest ultimate strength. As well as, the (*BTPB-Group*) produced the lowest slip and both the *BHS-Group* and *BCPB-Group* produced the highest slip, at ultimate stage. The deflections are varied between the three groups, it's clearly shown that the *BCPB-Group* gives the highest deflection. The tests results of the three groups are plotted in Figure 8 and Figure 9 in terms of load-slip at end of beam and load-deflection at mid-span of beam respectively. The experimental results show that the common shape of failure is the shear failure, for the three test groups. The results of the five groups listed in Table (4) show that, using perfobond connector in composite beam enhance the behavior of the beam represented by reducing deflection and slip and

increasing the resistance. Whereas, yield load resistance increase comparing with the stud connector's group of about (8.1% to 16%) and (14.9% to 23.2%) for circular and triangular continuous perfobond connectors' groups respectively. Also, the ultimate load resistance increase comparing with the stud connector's group of about (11.5% to 21.7%) and (12.5% to 22.6%) for circular and triangular perfobond connectors' groups respectively. The results shown in Figure 8 and Figure 9 show that the loads required to obtain the slips of beams with perfobond connectors are more than that required for stud connector. Table 4 also shows that, resistance are increased of about 7% and 1% at yield and ultimate stages respectively, for beams with triangular perfobond connectors' groups comparing with beams with circular connector's group. It is clearly shown that, the resistance gained from composite beams with triangular perfobond is more than that gained from the same beam with circular perfobond connectors. These results approved the applicability and validity of using the newly suggested type of perfobond connector. However, another goal of the research is to investigate the effects of method of distribution of perfobond connectors. The results listed in Table (4) and shown in Figure 8 and Figure (9) show clearly that, both circular and triangular perfobond connectors give more resistance and lesser slips and deflection when continuous perfobond connectors are used. Table (4) also showed the deflection results obtained from the ASD (allowable stress design) method of analysis and design of steel structures<sup>[7]</sup>. The design of the beam considered the fully composite section, therefore, the slip assumed to be zero.

### Conclusions

This paper described an experimental study that focused on the behavior and strength of steel–concrete composite beams with different types of shear connectors. The main conclusions drawn from this study are the following.

- Steel-concrete composite beams designed and constructed with perfobond shear connectors can develop higher strength compared with those constructed with stud shear connectors.
- The tests confirmed that the newly suggested triangular perfobond connector is applicable and give a higher strength than the circular perfobond connector and stud connector.
- The results indicate that the perfobond connectors arranged separately gave lesser resistance and higher slips comparing with continuously arranged perfobond connectors.

### Acknowledgement

This work is a part of an M.Sc. research project, in Civil Engineering Department, College of Engineering, Mosul University. The authors would like to thank the Civil Engineering laboratory staff in College of Engineering, University of Mosul for their cooperation.

### References

1. Al-Juboory, I.M.A., 2011, *Study of the Mechanical Shear Connectors Behaviour in Composite Beams (Steel-Concrete)*, M.Sc.Thesis, Civil Engineering Department, University of Mosul, Iraq.
2. BS.882-1992, *Aggregates from Natural Source for Concrete*, British Standard Institution, 1992.
3. Iraqi Specifications IQS No. 5, 1984, *Properties of Normal Portland Cement*, Iraqi Central Organization of

Standardization and Quality Control , Ministry of Planning, Iraq.

4. Knowles, P.R. 1973. *Composite Steel and Concrete Construction*. Butterworth Co. Ltd., London, , ISBN: 040870439X, 200pp.
5. Lawson, R.M., and Chun, K.F., 1994. *Composite Beam Design to Eurocode 4*, SCI Publication, Berkshire, U.K., ISBN: 1870004868, 135pp. [http://ebookey.org/Composite-Beam-Design-to-Eurocode-4\\_171860.html](http://ebookey.org/Composite-Beam-Design-to-Eurocode-4_171860.html)
6. Oehlers, D.J., Nguyen, N.T., Ahmed, M., and Bradford, M.A.; (1997), *Partial Interaction in Composite Steel and Concrete Beams with Full Shear Connection*, Journal of Constructional Steel Research, Vol.41, No.2/3, pp.235-248.
7. Salmon, C.G., and Johnson, J.E., (1980), "Steel Structures Design and Behavior", Harper & Row Publishers, Inc., New York, USA, 513pp.

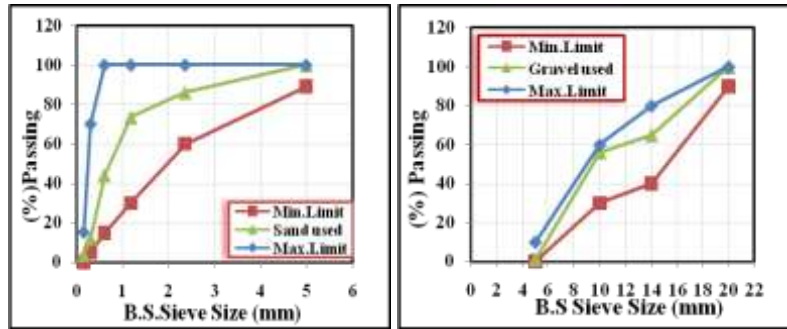

(a) Sand (b) Gravel  
 Figure (1) Sieve Analysis of (a) Sand and (b) Gravel

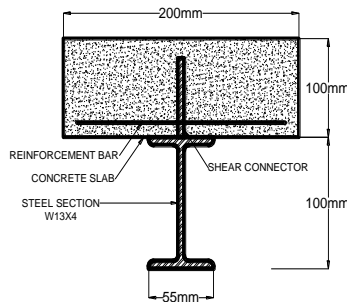
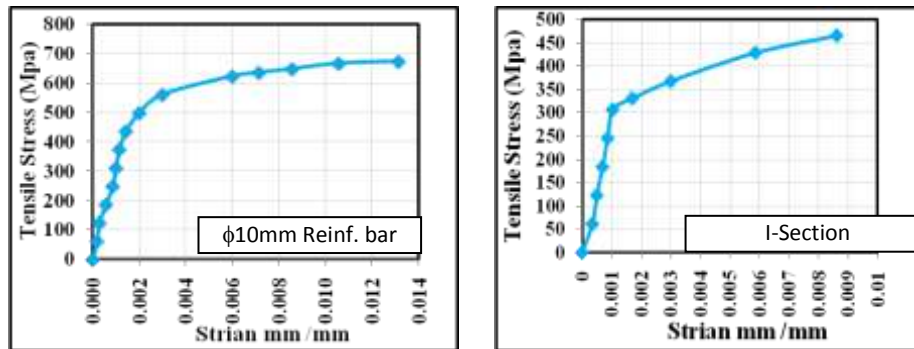

Figure (2) Beam Geometry



(a) Reinforcement Bar (b) Steel Section

Figure (3) Stress-Strain Relationship of (a) Reinforcement bar and (b) Steel Sections.

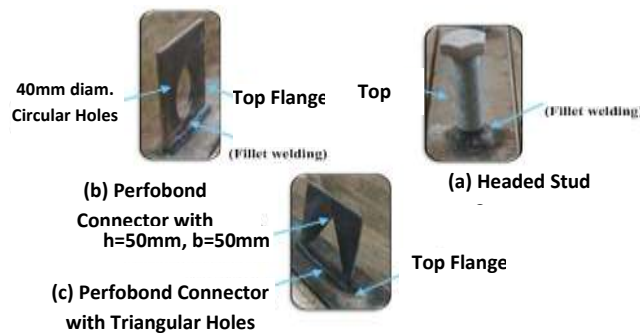

Figure (4) Connectors, (a) Stud, (b) Circular Perforated & (c) Triangular Perforated.

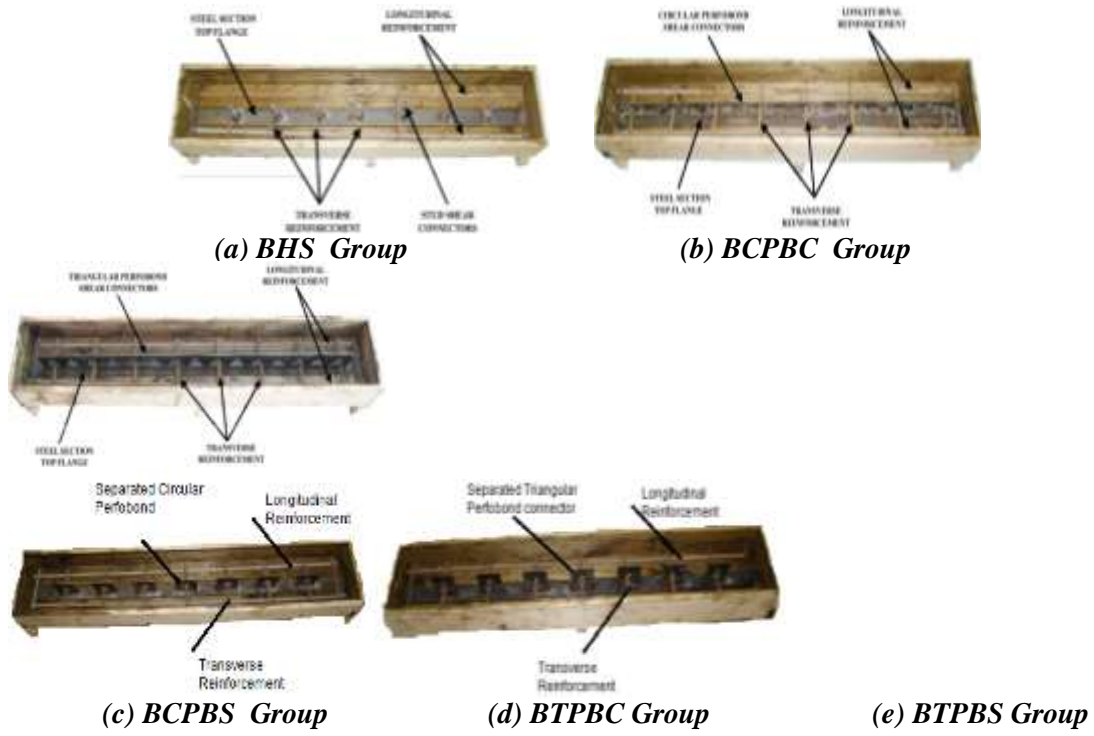

Figure (5) Steel parts, connectors and wood forms of the Composite Beam

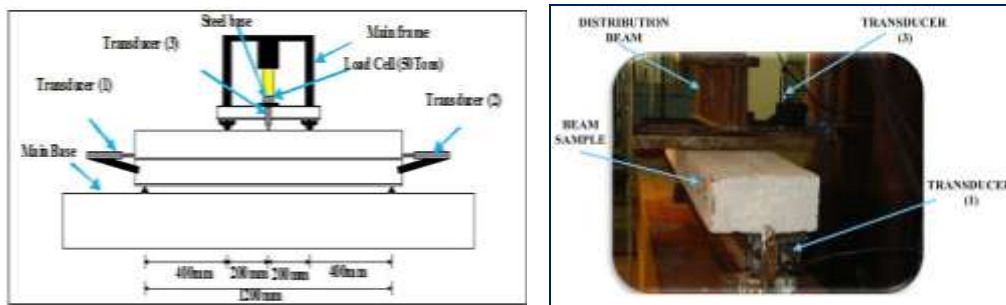

Figure (6) Dimensions and Loading Condition of Beam Specimen



Figure (7) Failure Shape of Tested Beams Sample

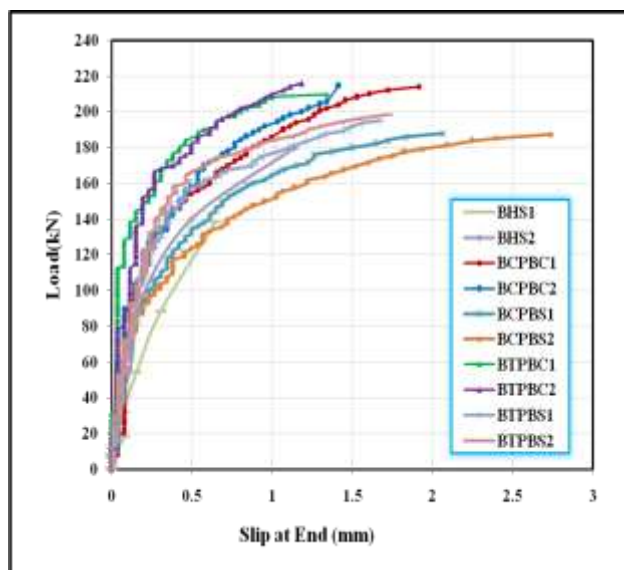

Figure (8) Load-Slip Test Results

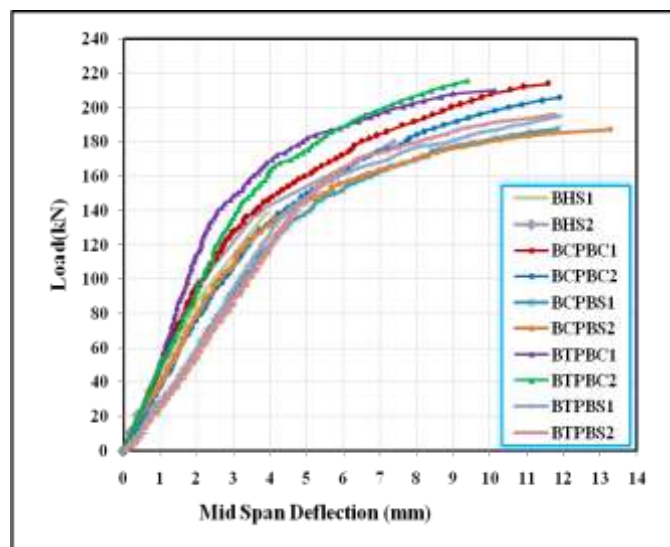

Figure (9) Load-Deflection Test Results

**Table (1) The chemical and physical tests results of cement**

Chemical test			Physical test		
Elements	Results %	IQS:No.5/1984 %	Properties	results	IQS:No.5/1984 %
Al <sub>2</sub> O <sub>3</sub>	5.6	3.0-8.0	Fineness remain on sieve170	7%	≤ 10%
SiO <sub>2</sub>	21.6	17.0-25.0	Initial Hardening (minute)	120	≥ 45 minute
Fe <sub>2</sub> O <sub>3</sub>	2.5	0.5-6.0	Final Hardening (minute)	360	≥ 600 minute
CaO	62.5	60.0-67.0	Comp. strength MPa-3days	18	≥ 16 MPa
SO <sub>3</sub>	2.6	≤ 2.8 %	Comp. strength MPa -7days	25	≥ 24 MPa
MgO	3.25	≤ 5%	Tension strength MPa-3days	2.0	≥ 1.6 MPa
C <sub>3</sub> S	36.44	31.03-41.05	Tension strength MPa-7days	3.5	≥ 2.4 MPa
C <sub>2</sub> S	34.20	28.61-37.90			
C <sub>3</sub> A	12.07	11.96-12.30			
C <sub>4</sub> AF	7.98	7.72-8.02			

**Table (2) Steel section and reinforcement yield strength and concrete compressive strength**

Steel Sec.	$f_y$ N/mm <sup>2</sup>	Concrete cube	$f_{cu}$ N/mm <sup>2</sup>	Reinf. Bar	$f_y$ N/mm <sup>2</sup>
1	340	1	28	1	565
2	325	2	24	2	555
3	328	3	25	3	569
4	330	4	26	4	557
5	338	5	28	5	561
6	324	6	26	6	563
<b>Average</b>	<b>331</b>	<b>Average</b>	<b>26.167</b>	<b>Average</b>	<b>561.167</b>

**Table(3) Yield strength, ultimate strength and modulus of elasticity of connectors**

Type of connector	$f_y$ N/mm <sup>2</sup>	$f_{ult.}$ (N/mm <sup>2</sup> )	$E$ (N/mm <sup>2</sup> )
Headed Stud	582	698	197500
Perfobond with Circular holes	562	675	194350
Perfobond with Triangular holes	562	675	194350

**Table (4) Testing Matrix and Experimental Results**

Specimen	Connector type	$P_{yield}$ kN	$P_{ult.}$ kN	$\delta_{ult.}$ mm	ASD $\delta_{ult.}$ mm	Slip mm
BHS1	Headed stud	138.0	176.0	8.35	3.65	1.49
BHS2	Headed stud	148.0	192.0	10.52	3.91	1.83
BPCBC1	Circular perfobond - Continuous	160.0	214.1	10.58	4.23	1.91
BPCBC2	Circular perfobond- Continuous	159.8	206.0	11.89	4.23	1.34
BPCBS1	Circular perfobond- Saparated	154.0	187.8	11.85	4.07	2.07
BPCBS2	Circular perfobond- Saparated	156.0	187.4	13.27	4.12	2.73
BTPBC1	Triangular perfobond- Continuous	170.0	210.0	10.13	4.49	1.34
BTPBC2	Triangular perfobond- Continuous	171.0	215.9	9.37	4.52	1.18
BTPBS1	Triangular perfobond- Separated	160.0	195.0	11.86	4.23	1.67
BTPBS2	Triangular perfobond- Separated	169.0	198.0	11.89	4.47	1.72